



# City of High Point

Municipal Office Building  
211 S. Hamilton Street  
High Point, NC 27260

## Meeting Agenda

### Finance Committee

*Britt Moore, Chair*  
*Committee Members:*  
*Monica Peters*  
*Michael Holmes*  
*Tim Andrew*

*Cyril Jefferson, Mayor (Alternate)*  
*Michael Holmes, Mayor Pro Tem (Alternate)*

---

Thursday, February 1, 2024

4:00 PM

3rd Floor, Council Chambers

---

### CALL TO ORDER

### FINANCE COMMITTEE - Britt W. Moore, Chair

### PRESENTATION OF ITEMS

- [2024-027](#) Consideration of a Renewal Contract with Accruent, a Sole Source Vendor, for the Computerized Maintenance Management System Software (CMMS)  
City Council is requested to approve Accruent as a sole source vendor for the renewal contract for CMMS Software in the amount of \$59,919.43 and authorize the appropriate City Official(s) to execute all necessary documents.  
*Attachments:* [Contract - Accruent - CMMS Software Renewal](#)
- [2024-029](#) Consideration of a Contract with Breece Enterprises  
City Council is requested to approve a contract with Breece Enterprises in the amount of \$1,337,803.00 for improvements along Kensington Dr. including stream restoration along Payne Creek Tributary and authorize the appropriate City Official(s) to execute all necessary documents.  
*Attachments:* [Contract - Breece Enterprise](#)
- [2024-031](#) Consideration of a Task Order with HDR Engineering  
City Council is requested to approve a Task Order with HDR Engineering in the amount of \$378,900 for professional engineering services to evaluate the Shadybrook sanitary sewer system and authorize the appropriate City Official(s) to execute all necessary documents.  
*Attachments:* [Task Order - HDR- Shadybrook Sewer Improvements](#)
- [2024-032](#) Consideration of a Task Order with HDR Engineering  
City Council is requested to approve a Task Order with HDR Engineering

in the amount of \$344,400 for professional engineering services to upgrade filters 1-4 at the Ward Water Treatment Plant and authorize the appropriate City Official(s) to execute all necessary documents.

**Attachments:** [Task Order - HDR Engineering- Ward Filter Rehabilitation Evaluation](#)

5. [2024-033](#) Consideration of Contract Amendment #1 to Machinex  
City Council is requested to approve contract amendment #1 to Machinex in the amount of \$196,820.00, increasing the amount of purchase order 112532 to \$1,496,820.00 and authorize the appropriate City Official(s) to execute all necessary documents.  
**Attachments:** [Contract - Machinex Amendment 1 MRF Baler](#)
6. [2024-030](#) Consideration of a Nonprofit Organization Agreement with High Point Market Authority  
City Council is requested to approve a Nonprofit Organization Agreement with High Point Market Authority and authorize the appropriate City Officials to execute all necessary documents.  
**Attachments:** [HPMA Nonprofit Agreement](#)
7. [2024-034](#) Consideration of a Contract with Community Housing Solutions  
City Council is requested to approve a contract with Community Housing Solutions in the amount \$419,184 to construct six affordable homes in the Cedrow Affordable Housing Project, adopt a resolution approving conveyance of real property to a nonprofit corporation, and authorize the appropriate City Official(s) to execute all necessary documents.  
**Attachments:** [Contract and Resolution - Community Housing Solutions](#)
8. [2024-035](#) Consideration of Acceptance of a Grant Award from the U.S. Small Business Administration  
City Council is requested to accept a grant award from the U.S. Small Business Administration in the amount of \$2,000,000 for development of a commercial shared-use kitchen, approve a budget ordinance amendment, and authorize the appropriate City Official(s) to execute all necessary documents.  
**Attachments:** [SBA Grant - Commercial Shared Use Kitchen](#)
9. [2024-036](#) Consideration of a Contract with Excel Truck Group  
City Council is requested to award a contract to Excel Truck Group in the amount of \$156,642.00 for the purchase of 2024 Freightliner M2 106 Plus and authorize the appropriate City Official(s) to execute all necessary documents.  
**Attachments:** [Contract - Excel Truck Group](#)
10. [2024-037](#) Consideration of a Contract with Triangle Grading and Paving, Inc.  
City Council is requested to approve a contract award to Triangle Grading and Paving, Inc. in the amount of \$4,299,385.30 for the Samet Drive Extension Project, adopt a capital project ordinance amendment, and

authorize the appropriate City Official(s) to execute all necessary documents.

***Attachments:*** [Contract - Triangle Grading and Paving, Inc - Samet Drive Extension](#)

11. [2024-038](#)

Consideration of a Task Order with Michael Baker International  
City Council is requested to approve a task order with Michael Baker International in the amount of \$275,000 for construction inspection and materials testing services for the Samet Drive Extension project, adopt a capital project ordinance amendment, and authorize the appropriate City Official(s) to execute all necessary documents.

***Attachments:*** [Task Order - Michael Baker International- Samet Drive Extension Inspection and](#)

12. [2024-040](#)

Consideration of Contract with Trademark Properties  
City Council is requested to approve a contract with Trademark Properties in the amount of \$120,000 to perform advisory services for planning, construction and delivery of a new City Hall and associated uses at 405 N. Main Street and authorize the appropriate City Official(s) to execute all necessary documents.

***Attachments:*** [Contract - Trademark Properties](#)

## **ADJOURNMENT**



# City of High Point

Municipal Office Building  
211 S. Hamilton Street  
High Point, NC 27260

## Master

**File Number: 2024-027**

**File ID:** 2024-027

**Type:** Miscellaneous Item

**Status:** To Be Introduced

**Version:** 1

**Reference:**

**In Control:** Finance Committee

**File Created:** 01/22/2024

**File Name:**

**Final Action:**

**Title:** Consideration of a Renewal Contract with Accruent, a Sole Source Vendor, for the Computerized Maintenance Management System Software (CMMS)  
City Council is requested to approve Accruent as a sole source vendor for the renewal contract for CMMS Software in the amount of \$59,919.43 and authorize the appropriate City Official(s) to execute all necessary documents.

**Notes:**

**Sponsors:**

**Enactment Date:**

**Attachments:** Contract - Accruent - CMMS Software Renewal

**Enactment Number:**

**Contact Name:**

**Hearing Date:**

**Drafter Name:** tammie.dodd@highpointnc.gov

**Effective Date:**

### History of Legislative File

Ver- sion:	Acting Body:	Date:	Action:	Sent To:	Due Date:	Return Date:	Result:

# CITY OF HIGH POINT

## AGENDA ITEM



<b>TITLE:</b> Annual Computerized Maintenance Management System (CMMS) Software Renewal - Accruent	
<b>FROM:</b> Robby Stone – Public Services Director Derrick Boone – Asst. Public Services Director	<b>MEETING DATE:</b> February 5, 2024
<b>PUBLIC HEARING:</b> No	<b>ADVERTISED DATE/BY:</b> N/A
<b>ATTACHMENTS:</b> Attachment A – Sole Source Form Attachment B- Quote	

**PURPOSE:** To renew the annual contract with Accruent, sole source vendor, for the computerized maintenance management system (CMMS).

**BACKGROUND:** A computerized maintenance management system (CMMS) is software that centralizes maintenance information and facilitates the processes of maintenance operations. It helps optimize the utilization and availability of physical equipment like vehicles, machinery, communication, plant infrastructure and other assets. The Water and Sewer Plant Maintenance Division utilizes Accruent CMMS software for tracking the operation, maintenance, and replacement of equipment at the water and wastewater facilities. This is a one-year contract renewal which will be in place until we transition to the Cityworks work order management software.

**BUDGET IMPACT:** Funding is available in the FY 2023-2024 budget.

**RECOMMENDATION/ACTION REQUESTED:** The Public Services Department is recommending that Accruent be approved as a sole source vendor for the annual renewal of the CMMS software for \$59,919.43.



Financial Services

Purchasing Division



NORTH CAROLINA'S INTERNATIONAL CITY™

Requisition # 37262

CITY OF HIGH POINT
SOLE SOURCE JUSTIFICATION FORM
(For Items Costing \$10,000.00 or More)
Statutory Reference N.C.G.S. 143-129(e)6

Vendor: Accruent

Item(s): Maintenance Connection annual renewal

Justification:
The Water and Sewer Plant Maintenance Division utilizes Accruent CMMS software for tracking the operation, maintenance, and replacement of equipment at the water and wastewater facilities.

Estimated expenditure for the above item(s): \$59,919.43

Accounting Unit and Account(s): 621757-527101

CHECK ALL ENTRIES BELOW THAT APPLY TO THE PROPOSED PURCHASE. ATTACH A MEMO CONTAINING JUSTIFICATION AND SUPPORT DOCUMENTATION.

- 1. [checked] Performance or price competition for a product are not available.
2. [checked] A needed product is available from only one source of supply.
3. [checked] Standardization or compatibility is the overriding consideration.
4. [ ] The parts/equipment are required from this source to permit standardization.
5. [ ] None of the above applies. A detailed explanation and justification for this sole source request is contained in attached memo and support documentation.

The undersigned requests that competitive procurement be waived and that the vendor identified as the supplier of the material or service described in this sole source justification be authorized as a sole source for the material or service.

Department Head/Authorized Personnel Robby Stone Digitally signed by Robby Stone Date: 2024.01.22 08:26:08 -05'00'

Department/Division Public Services - W/S Maintenance Date 1-22-2024

APPROVAL PROCESS

Purchasing Manager
Financial Services Director
City Council (\$30,000 – Up)

### Client Information

<b>Client Name:</b>	City of High Point	<b>Client Contact Name:</b>	Rick Riley
<b>Bill To:</b>	Casey Miller PO Box 230 High Point, NC 27261 United States	<b>Client Contact Email:</b>	rick.riley@highpointnc.gov
<b>Ship To:</b>	Kim Hilton 121 N Pendleton St High Point, NC 27260 United States	<b>Client Contact Phone:</b>	+1 03368838588
<b>Billing Email:</b>	casey.miller@highpointnc.gov	<b>Account Number:</b>	A-00130059

### Quote Information

<b>Quote #:</b>	Q-273762-1	<b>Quote Expiration:</b>	2/16/2024
<b>Start Date:</b>	2/19/2024	<b>End Date:</b>	2/18/2025
<b>Invoice Frequency:</b>	Annual		

### Product Information and Fees

Product	Quantity	Period 2/19/2024 - 2/18/2025	Total Fees
MC Annual Technical Support - Renewal	21 Concurrent License(s)	26,682.19	USD 26,682.19
MC Annual Technical Support - Renewal	19 Concurrent License(s)	7,505.12	USD 7,505.12
MC Secure Datacenter Hosting Cloud Subscription	20 License(s)	25,732.12	USD 25,732.12
<b>Total</b>		<b>USD 59,919.43</b>	<b>USD 59,919.43</b>

## Additional Terms

- 1 If the invoice period reflects a term of less than 12 months, the recurring fees are prorated and will renew as permitted under the Agreement at the annualized rate.
- 2 The pricing and offer in this Order Document are provided in return for an executed Order Document received by Accruent by the Quote Expiration date listed above.
- 3 Unless Client has a separate negotiated master services agreement or other binding agreement in place with Accruent, by signing below, Client agrees that this Order Document is subject to the end user license agreement set forth at: [https://www.accruent.com/end\\_user\\_license\\_agreement](https://www.accruent.com/end_user_license_agreement)

## Acknowledged and Agreed by the Duly Authorized Representatives of the Parties

<b>Client: City of High Point</b>	<b>Accruent, LLC</b>
<b>Signature:</b>	<b>Signature:</b>
<b>Print Name:</b>	<b>Print Name:</b>
<b>Title:</b>	<b>Title:</b>
<b>Date:</b>	<b>Effective Date:</b>
<b>Accruent requires a PO, send PO to your Accruent representative or <a href="mailto:customerpo@accruent.com">customerpo@accruent.com</a>. To avoid invoicing issues or a potential disruption in your services, please include the Quote # above in your PO.</b>	
<b>If you are tax exempt, provide exemption certification to your Accruent representative or <a href="mailto:salestax@accruent.com">salestax@accruent.com</a>.</b>	





# City of High Point

Municipal Office Building  
211 S. Hamilton Street  
High Point, NC 27260

## Master

**File Number: 2024-029**

**File ID:** 2024-029

**Type:** Miscellaneous Item

**Status:** To Be Introduced

**Version:** 1

**Reference:**

**In Control:** Finance Committee

**File Created:** 01/18/2024

**File Name:**

**Final Action:**

**Title:** Consideration of a Contract with Breece Enterprises  
City Council is requested to approve a contract with Breece Enterprises in the amount of \$1,337,803.00 for improvements along Kensington Dr. including stream restoration along Payne Creek Tributary and authorize the appropriate City Official(s) to execute all necessary documents.

**Notes:**

**Sponsors:**

**Enactment Date:**

**Attachments:** Contract - Breece Enterprise

**Enactment Number:**

**Contact Name:**

**Hearing Date:**

**Drafter Name:** dona.turner@highpointnc.gov

**Effective Date:**

### History of Legislative File

Ver- sion:	Acting Body:	Date:	Action:	Sent To:	Due Date:	Return Date:	Result:
---------------	--------------	-------	---------	----------	-----------	-----------------	---------

# CITY OF HIGH POINT

## AGENDA ITEM



<b>TITLE:</b> Kensington - Dovershire Improvement, Breece Enterprises - Bid 22-010424	
<b>FROM:</b> Robby Stone – Public Services Director Melinda King – Asst. Public Services Director	<b>MEETING DATE:</b> February 5, 2024
<b>PUBLIC HEARING:</b> No	<b>ADVERTISED DATE/BY:</b> October 5, 2023 Purchasing
<b>ATTACHMENTS:</b> Attachment A – Bid Tabulations Attachment B - Design Plan Sheet Attachment C – Recommendation Form	

**PURPOSE:** To make stormwater and sanitary sewer pipe improvements along Kensington Dr. including stream restoration along Payne Creek Tributary.

**BACKGROUND:** The Emerywood Forest community has experienced flooding due to capacity issues within the existing system for several years as well as stream erosion. Community outreach meetings were held to determine the concerns and evaluate potential solutions. The project involves stormwater improvements along Kensington Dr. and a stream restoration section adjacent to Kensington Dr. The improvements consist of relocating the existing storm drain along Kensington Dr. from Ashely Ave to Dovershire Pl. from private property to the right-of-way. The new stormwater line will tie into the existing outlet of the culvert headwall crossing Kensington Ave. which will allow more capacity within the culvert from upstream flow. A small section of stream restoration along the Payne Creek Tributary will be completed to reduce erosion of the stream bank.

All Easements and Right-of-Ways have been acquired from applicable property owners within this corridor. All permits have been acquired as well. The estimated timeframe for completion of the improvements is 270 calendar days.

A total of two (2) bids were received on November 30, 2023. The project was re-advertised and opened on January 4, 2024. Three (3) bidders responded for the re-advertised project. Breece Enterprises was the lowest bidder.

**BUDGET IMPACT:** Funds for this project are available in the FY 2023-2024 budget Stormwater Capital Projects Fund.

**RECOMMENDATION/ACTION REQUESTED:** The Public Services Department recommends approval of the contract and that the appropriate City official and/or employee be authorized to execute all necessary documents to award the project to Breece Enterprises in the amount of \$1,337,803.00.



**Bid Tabulation**

Bid # 22010424

Rebid-Kensington Dovershire Improvement

Thursday, January 4, 2024,@ 2:00 PM

<b><u>BIDDERS</u></b>	<b><u>TOTAL BID</u></b>
Breece Enterprises 631 Old Thomasville Road High Point NC 27260	\$1,337,803.00
Country Boy Landscaping P O Box 290 Harmony, NC 28634	\$1,779,904.50
O L Parker & Son Grading 2742 Miranda Road Charlotte NC 28216	\$1,414,400.00

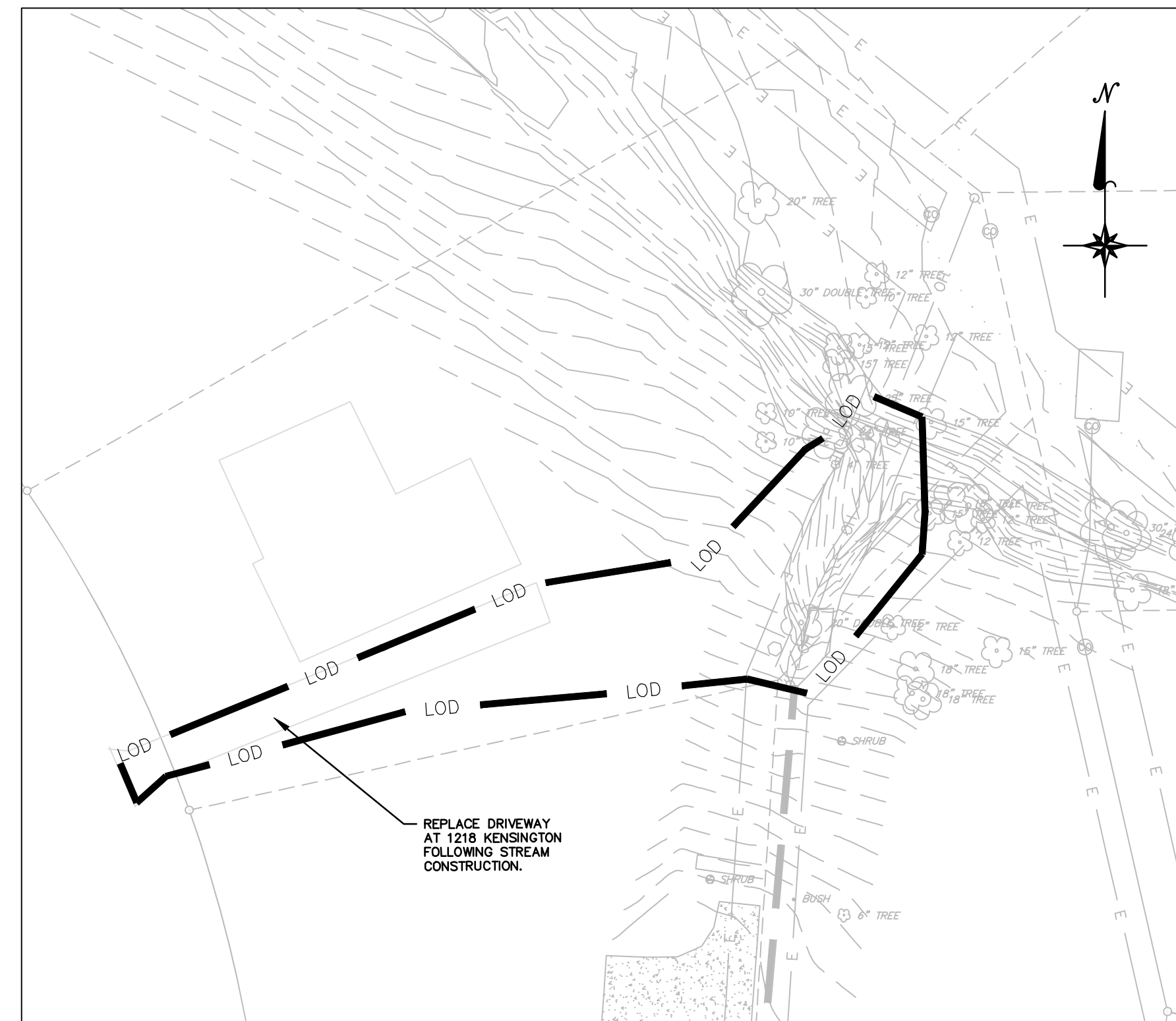
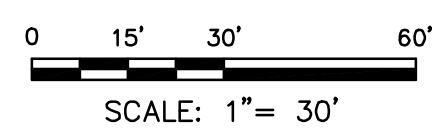
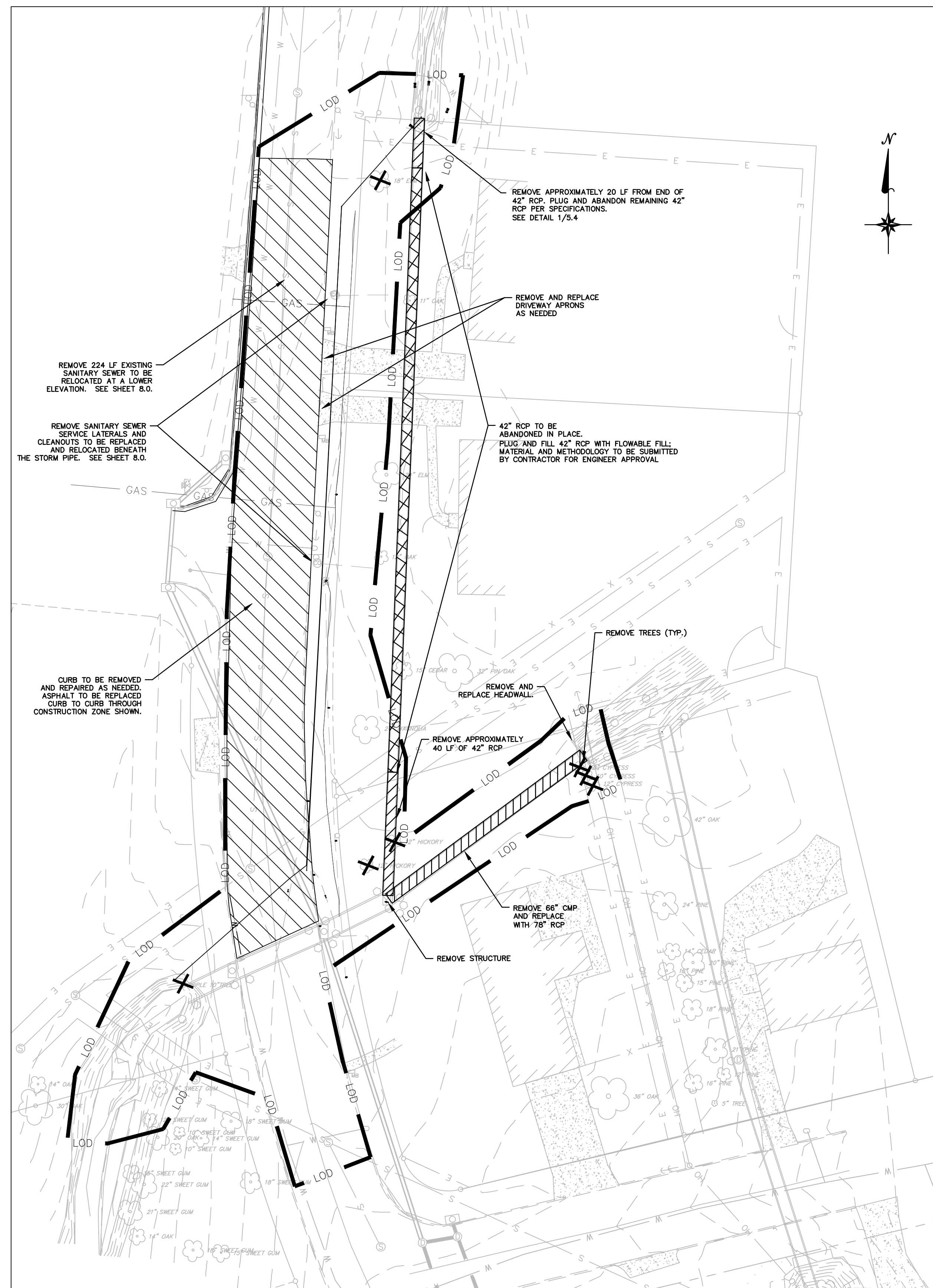

**DEMOLITION NOTES:**

1. DEMOLITION SHALL INCLUDE THE REMOVAL FROM THE SITE OF TREES WHERE NOTED, STUMPS, BRUSH, VEGETATION, TRASH, DEBRIS, WASTE STONE, WASTE PIPING/STRUCTURES, AND ANY OTHER UNSUITABLE MATERIAL FROM WITHIN THE PROJECT AREA BOUNDARY AND CLEARING LIMITS, UNLESS INDICATED OTHERWISE ON THESE PLANS OR DIRECTED BY THE ENGINEER.
2. TREES ALONG THE OUTFALL AND WITHIN PORTIONS OF THE CONSTRUCTION LIMITS THAT DO NOT CONFLICT WITH CONSTRUCTION SHALL REMAIN AND BE PROTECTED FROM DAMAGE, UNLESS OTHERWISE DIRECTED BY THE ENGINEER.
3. DEMOLITION SHALL INCLUDE THE REMOVAL OF ALL DEBRIS AT ALL DRAINAGE DEVICES. THE REMOVAL OF DEBRIS SHALL BE MAINTAINED BY THE CONTRACTOR TO ALLOW CONSTANT DRAINING OF THE DEVICES DURING CONSTRUCTION.
4. ALL WORK SHALL BE PERFORMED WITHIN THE PUBLIC RIGHT-OF-WAY AND EASEMENTS WITHIN THE PROJECT AREA AS SHOWN ON THE PLANS.
5. EXISTING STORM DRAINAGE PIPES TO BE ABANDONED SHALL BE ABANDONED IN PLACE, UNLESS PIPE WILL BE EXPOSED FOR PROPOSED CONSTRUCTION. EXPOSED PIPE SHALL BE REMOVED AS WASTE MATERIAL. ABANDONED PIPE SHALL BE PLUGGED AND FILLED. CONTRACTOR SHALL INSTALL A MASONRY PLUG IN ACCORDANCE WITH NCDOT STANDARDS (840.71) AND FILL EXISTING PIPE WITH CONCRETE OR GROUT. THIS CONCRETE OR GROUT SHALL BE A MINIMUM 2000 PSI AND SHALL BE PUMPED UNDER PRESSURE IN SUCH A MANNER TO ENSURE THAT THE LINE COMPLETE FILLS WITH THE CONCRETE OR GROUT.
6. INLET AND MANHOLE STRUCTURES TO BE REMOVED SHALL BE COMPLETELY EXCAVATED AND DISPOSED OF AS WASTE MATERIAL. SUITABLE FILL MATERIAL SHALL BE PROVIDED AS NEEDED TO RESTORE GRADE.
7. REMOVED STRUCTURE LOCATIONS OUTSIDE OF PAVEMENT AREAS SHALL HAVE AT LEAST 6 INCHES OF TOPSOIL AT FINISHED GRADE PRIOR TO SEEDING.
8. THE CONTRACTOR SHALL SAWCUT EXISTING ASPHALT AND/OR CONCRETE SURFACES PRIOR TO REMOVAL, UNLESS OTHERWISE DIRECTED BY THE ENGINEER. SAWCUT PAVEMENT SHALL BE REPLACED AS WELL AS ADDITIONAL PAVEMENT REQUIRED TO TIE-IN TO FACE OF PROPOSED CURB AND GUTTER, PAVEMENT, OR DRIVEWAY.
9. DRIVEWAYS SHALL BE REPLACED IN ACCORDANCE WITH CITY OF HIGH POINT STANDARDS TO A WIDTH TO MATCH THE EXISTING DRIVEWAY.
10. ALL SURPLUS EXCAVATION SHALL BE REMOVED FROM THE SITE BY THE CONTRACTOR. DISPOSAL SHALL COMPLY WITH ALL FEDERAL, STATE, AND LOCAL LAWS AND REGULATIONS.

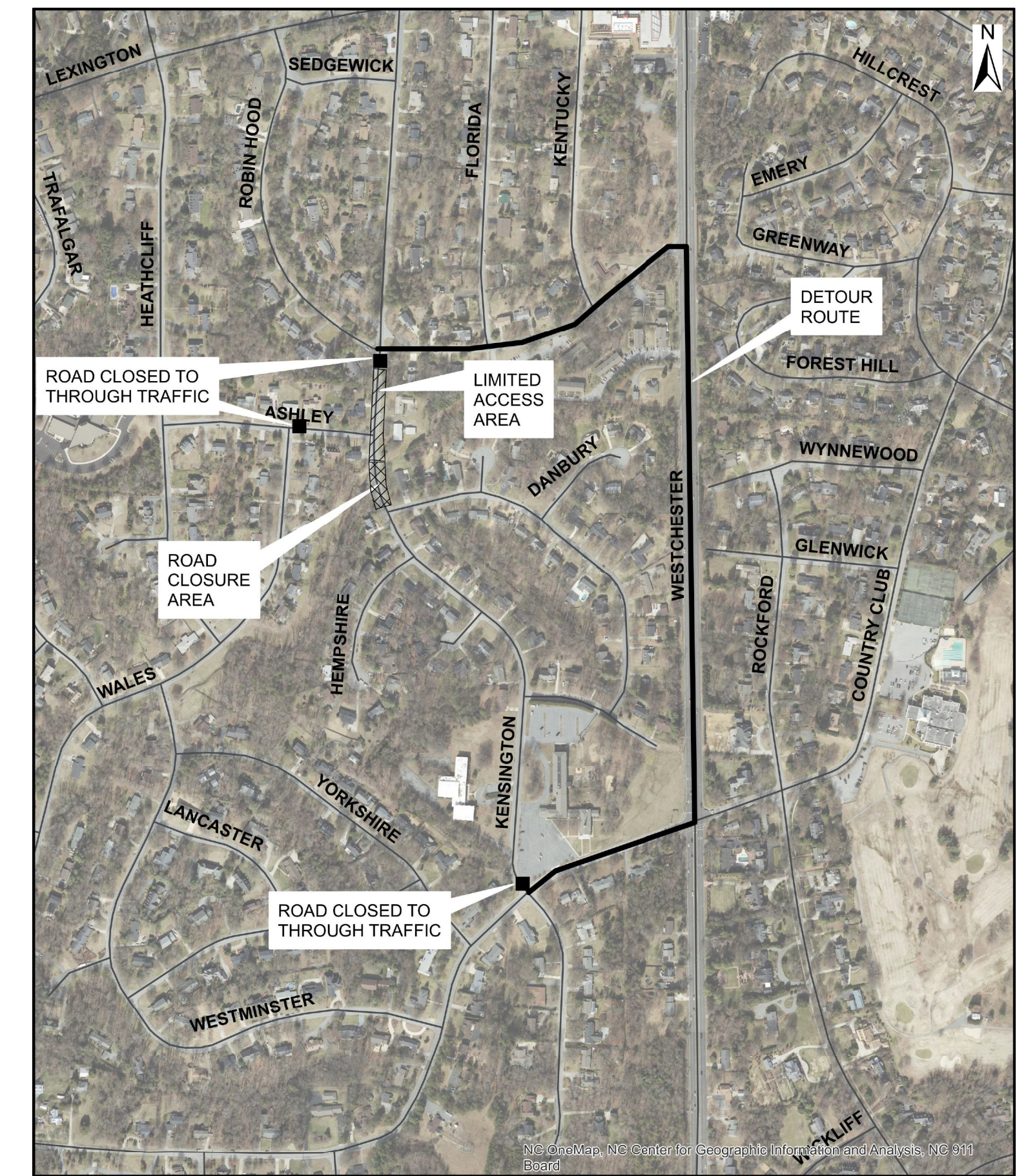

**TRAFFIC DETOUR ROUTE**

NOT TO SCALE

**TRAFFIC CONTROL NOTES:**

1. CONTRACTOR SHALL SUBMIT A TRAFFIC CONTROL PLAN FOR APPROVAL PRIOR TO THE START OF CONSTRUCTION.
2. THE CONTRACTOR SHALL UTILIZE SIGNS, BARRICADES, FLAG MEN, OR GUARDS AS REQUIRED TO ENSURE THE SAFETY OF ALL VEHICULAR AND PEDESTRIAN TRAFFIC DURING ALL CONSTRUCTION ACTIVITIES.
3. ACCESS BY HOMEOWNERS TO THEIR RESIDENCES SHALL BE MAINTAINED AT ALL TIMES.
4. TRAFFIC CONTROL DEVICES, SIGNS, LANE CLOSURES, SIDEWALKS, ETC. SHALL BE INSTALLED IN ACCORDANCE WITH THE LATEST EDITION OF THE MANUAL ON UNIFORM TRAFFIC CONTROL DEVICES AND NCDOT STANDARDS.
5. TEMPORARY TRAFFIC CONTROL SIGNS TO REROUTE TRAFFIC OR CONTROL ROAD USERS SHALL BE INSTALLED NO LESS THAN 3 DAYS IN ADVANCE AND BAGGED AS NEEDED.
6. THE CONTRACTOR IS REQUIRED TO FURNISH, INSTALL, RELOCATE, AND MAINTAIN ALL TRAFFIC CONTROL MEASURES (SIGNS, BARRICADES, WARNING AND/OR CHANNELIZING DEVICES) FOR WORK SITES AND DETOUR ROUTES AS REQUIRED. THE LOCATION AND POSITIONING OF THESE TRAFFIC CONTROL MEASURES SHALL BE APPROVED BY THE ENGINEER.
7. MESH SIGNS ARE NOT PERMITTED FOR OVERNIGHT CLOSURES.

REV	REVISIONS	BY	DATE

ISSUE DATE:  
February 4, 2022

LJB PROJECT NUMBER:  
0118593A

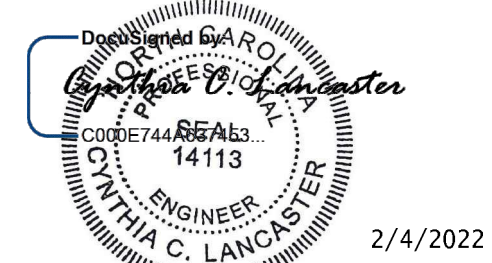

PREPARED BY:

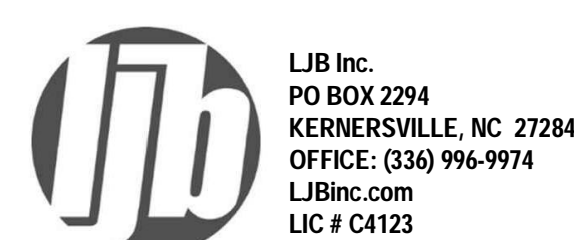

Stream Stabilization & Infrastructure Improvements - Kensington Drive & Dovershire Place

**DEMOLITION PLAN & TRAFFIC CONTROL PLAN**

SHEET NO.

**4.0**

**BID RECOMMENDATION**

DEPARTMENT:

COUNCIL AGENDA DATE:

BID NO.:  CONTRACT NO.:  DATE OPEN:

DESCRIPTION:

Due to flooding concerns by residents along Kensington Dr and Dovershire Pl, a stormwater improvement project upgrading the stormwater system, sewer relocation and stream restoration was design and bid for construction.

PURPOSE:

To contract installation of engineered plans for stormwater improvements, sewer relocation and stream restoration.

COMMENTS:

RECOMMEND AWARD TO:  AMOUNT:

JUSTIFICATION:

Lowest, responsible bidder.

ACCOUNTING UNIT	ACCOUNT	ACTIVITY	CATEGORY	BUDGETED AMOUNT
471710	533701	471241024105		1,587,600.00
TOTAL BUDGETED AMOUNT				

DEPARTMENT HEAD:  Digitally signed by Robby Stone Date: 2024.01.22 09:18:16 -05'00' DATE:

The Purchasing Division concurs with recommendation submitted by the  and recommends award to the lowest responsible, responsive bidder  in the amount of

PURCHASING MANAGER:  Digitally signed by Candy E. Harmon Date: 2024.01.22 09:41:52 -05'00' DATE:

FINANCIAL SERVICES DIRECTOR:  Digitally signed by Bobby Fitzjohn Date: 2024.01.25 13:06:01 -05'00' DATE:

Approved for Submission to Council

CITY MANAGER:  (For City Council Approval Only) DATE:



# City of High Point

Municipal Office Building  
211 S. Hamilton Street  
High Point, NC 27260

## Master

**File Number: 2024-031**

**File ID:** 2024-031

**Type:** Miscellaneous Item

**Status:** To Be Introduced

**Version:** 1

**Reference:**

**In Control:** Finance Committee

**File Created:** 01/24/2024

**File Name:**

**Final Action:**

**Title:** Consideration of a Task Order with HDR Engineering  
City Council is requested to approve a Task Order with HDR Engineering in the amount of \$378,900 for professional engineering services to evaluate the Shadybrook sanitary sewer system and authorize the appropriate City Official(s) to execute all necessary documents.

**Notes:**

**Sponsors:**

**Enactment Date:**

**Attachments:** Task Order - HDR- Shadybrook Sewer Improvements

**Enactment Number:**

**Contact Name:**

**Hearing Date:**

**Drafter Name:** dona.turner@highpointnc.gov

**Effective Date:**

### History of Legislative File

Ver- sion:	Acting Body:	Date:	Action:	Sent To:	Due Date:	Return Date:	Result:

# CITY OF HIGH POINT

## AGENDA ITEM



<b>TITLE:</b> Shadybrook Sewer Improvements – Professional Engineering Services HDR Engineering Inc.	
<b>FROM:</b> Robby Stone – Public Services Director Derrick Boone – Asst. Public Services Director	<b>MEETING DATE:</b> February 5, 2024
<b>PUBLIC HEARING:</b> N/A	<b>ADVERTISED DATE/BY:</b> Master Agreement - Task Order
<b>ATTACHMENTS:</b> Attachment A – Scope of Services Attachment B- Map	

**PURPOSE:** To approve a task order with HDR Engineering for the professional engineering services to evaluate the Shadybrook sanitary sewer system. The city has a master on-call agreement with HDR Engineering.

**BACKGROUND:** The Public Services Department utilized CDM-Smith to update the 2019 Wastewater Master Plan, which included the Shadybrook sanitary sewer system due to known capacity issues with the Shadybrook Lift Station. The expanded master plan includes a more detailed analysis of the Shadybrook sub-basin following the collection of additional data and hydraulic modeling in this basin. The expanded master plan recommended several improvements in the Shadybrook sub-basin and suggests that a preliminary engineering report (PER) be prepared to further evaluate and detail the anticipated improvements.

The following improvements will be evaluated by HDR and included in the PER:

- Capacity Expansion of the Shadybrook Lift Station.
- Upsizing gravity sewers upstream and downstream of the Shadybrook Lift Station.
- Upsizing the force main downstream of the Shadybrook Lift Station.

**BUDGET IMPACT:** Funds for this project are available in the FY 2023-2024 budget.

**RECOMENDATION/ACTION REQUESTED:** The Public Services Department recommends approval and asks for the Council to award this task order for professional engineering services to HDR Engineering Inc. in the amount of \$378,900 and authorize the appropriate City Official(s) to execute all necessary documents.



Shadybrook Lift Station

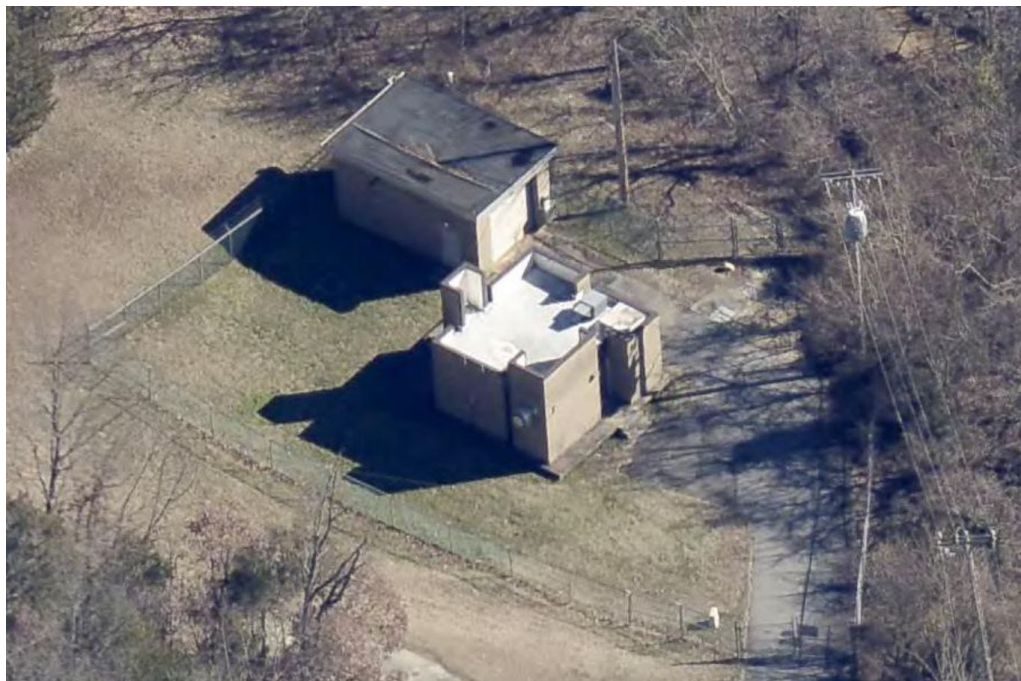

Aerial View of Shadybrook Lift Station and Generator Building





Dry Well of the Shadybrook Lift Station





## Supplemental Agreement

### Exhibit A

## Shadybrook Sewer Improvements PER

### Introduction

The City of High Point Public Services Department (City) owns, operates, and maintains a permitted wastewater collection and treatment system providing services to a mix of approximately 42,600 residential, commercial, and industrial customers. An estimated 16.8 million gallons of wastewater is generated, conveyed, and treated daily. The collection system includes approximately 680 miles of gravity sewer mainlines, 18 miles of pressurized force main, 17,450 manholes, and 22 lift stations. This collection system conveys wastewater flows to two wastewater treatment facilities – the Eastside Wastewater Treatment Plant with a permitted capacity of 26 million gallons per day (MGD) and Westside Wastewater Treatment Plant with a permitted capacity of 10 MGD.

### Scope of Services

The Owner recently completed an addendum, (CDM, November 2023), to the 2019 Wastewater Master Plan. The addendum, in part, included a more detailed analysis of the Shadybrook subbasin following the collection of additional data and hydraulic modeling in this subbasin. The addendum recommends several improvements in the Shadybrook subbasin and suggests that a preliminary engineering report (PER) be prepared to further evaluate and detail these improvements.

The following improvements will be evaluated and included in the PER and are further described in the paragraphs below:

- Capacity Expansion of the Shadybrook Lift Station.
- Upsizing gravity sewers upstream and downstream of the Shadybrook Lift Station.
- Upsizing the force main downstream of the Shadybrook Lift Station.

### Task 1: Shadybrook Lift Station

Engineer will evaluate alternatives and provide recommendations for increasing the capacity of the lift station. The analysis will be based on a design capacity of 4.83 MGD as recommended in the 2023 Master Plan Addendum.

#### TASKS WILL INCLUDE:

- Alternative analysis to compare the expansion of the existing lift station to the construction of a new adjacent lift station, to include:
  - Existing Lift Station
    - Perform a visual condition assessment of the existing lift station to include civil, structural, electrical, mechanical, and instrumentation components.
    - Identify needed improvements to meet capacity requirements and improve any condition issues identified.



- Using existing drawings, provided by the Owner, as background image, markup the existing drawings to identify proposed improvements.
- Prepare an opinion of probable construction costs based on the proposed improvements.
- New Lift Station
  - Perform a site review to consider available land, zoning, setbacks, environmental impacts, access, and constructability.
  - Develop a conceptual layout of a new submersible lift station.
  - Prepare an opinion of probable construction costs based on the conceptual layout.

### **Task 2: Shadybrook Gravity Sewers**

Engineer will evaluate alternatives and provide recommendations for replacing various gravity sewer sections upstream and downstream of the lift station to increase their hydraulic capacity. The gravity sewer sections include the following: 1,800 LF between the lift station and manhole HP24247; 900 LF between manholes HP17980 and HP10882; 1,200 LF between manholes HP24247 and HP18563; and 900 LF downstream of the lift station between manholes HP16869 and HP21383.

#### **TASKS WILL INCLUDE:**

- Alternative analysis to compare alternatives for increasing the size and capacity of each gravity sewer section.
  - Alternatives
    - Remove and replace existing pipe along the existing alignment.
    - Install parallel pipe along new alignment and abandoned existing pipe.
    - Pipe burst existing pipe.
  - Analysis to include:
    - Environmental impacts.
    - Property owner impacts.
    - Constructability challenges.
    - Bypass pumping requirements.
    - Estimated construction costs.

### **Task 3: Shadybrook Force Main**

Engineer will evaluate alternatives and provide recommendations for replacing a section of the existing force main downstream of the lift station to increase the hydraulic capacity. The force main section extends from the intersection of Rolling Road and Marywood Drive, along Rolling Road to just south of Parliament Street, and through residential laws to the intersection of Fairmeadow Avenue and Hollyfield Place.

#### **TASKS WILL INCLUDE:**

- Alternative analysis to compare alternatives for increasing the size and capacity of the force main section.
  - Alternatives
    - Remove and replace the existing force main along the existing alignment.



- Install parallel force main along new alignment and abandoned existing force main.
- Pipe burst existing force main.
- Analysis to include:
  - Environmental impacts.
  - Property owner impacts.
  - Constructability challenges.
  - Bypass pumping requirements.
  - Estimated construction costs.

#### **Task 4: Planning Data Review & Capital Project Analysis**

In parallel with the development of the Shadybrook Sewer Improvements PER, the Engineer will evaluate the methodology, flow monitoring data, and assumptions used to develop the Shadybrook improvements along with the broader Wastewater Master Plan.

##### **TASKS WILL INCLUDE:**

- A comprehensive review of the means and methods, along with the associated analysis, used to identify and develop individual projects included in the Capital Improvement Plan (CIP).
  - Model Development Review
    - Review the development of the existing and future system hydraulic model including system loading, network development, model calibration and key assumptions. Compare methodologies and assumptions to regulatory requirements and industry prevalent guidelines and provide a summary of recommendations.
  - Shadybrook Projects
    - Review the hydraulic model, associated flow monitoring data, and modeled loading to confirm the strategy, size, and extent of the Shadybrook sewer improvements.
  - Overall Capital Improvement Plan
    - Review the hydraulic model, associated flow monitoring data, and modeled existing and future system loading for consideration of the overall CIP.
    - This review will identify potential opportunities for additional field activity to confirm, reprioritize, or reconsider CIP projects through targeted monitoring of specific locations or other field activities.
- Evaluation of the full CIP portfolio to identify additional considerations for downstream infrastructure including treatment facilities and opportunities for alternative, cost-saving approaches.
  - Treatment Facilities
    - Confirm coordination of projected loading and future flows identified for the collection system with treatment facility capacity and capacity improvements. Review methodologies for determining treatment plant expansion/improvement triggers and compare to regulatory and industry prevalent guidelines.
  - System Condition



- Review of asset information to identify condition-based risk within the collection system to prioritize condition assessment activities.
- A Sanitary Sewer Evaluation Survey (SSES) approach will be developed to collect condition data on collection system pipes and evaluate repair according to risk-model results..
- Alternative Approaches
  - Identify alternatives to convey and treat approaches associated with increases in collection system flow.
  - Potential options include condition assessment and rehabilitation efforts to reduce inflow, infiltration, peak flow volumes, and other factors driving the need for capital investment.

### **Project Meetings**

To assist with the evaluations and PER development, and to communicate activities with the Owner, the following meetings are anticipated:

- Project Kick-Off Meeting
  - Review project scope and schedule.
  - Discuss initial steps, activities, and data needs.
  - Discuss current operations, concerns, likes/dislikes of the existing lift station and obtain input on expansion of the existing lift station and a new lift station.
    - Meeting to include the Owner's lift station operation staff.
- Lift Station Site Meeting
  - Visit the existing lift station to perform visual assessment.
  - Meeting to include the Owner's lift station operation staff.
  - Meeting will be schedule for same day, and immediately following, the Project Kick-off Meeting.
- Alternative Review and Selection Meeting
  - Review the alternative analysis performed to compare expansion of the existing lift station to construction of a new lift station.
  - Review the alternative analysis performed for the upsizing of the gravity sewers and force main.
  - Make selections of the preferred alternatives.
- PER Review Meeting
  - Discuss findings and recommendations, and receive comments from the Owner on their review of the draft PER.
  - Comments received and discussion will be used to prepare the final PER.

### **Assumptions & Exclusions**

- No flow monitoring or flow projection development is included. Minor hydraulic modeling may be performed to determine potential impacts of alternatives to convey and treat methodologies, but results will be limited to broad recommendations.
- Recommendations for additional field investigation including flow monitoring and detailed hydraulic modeling will be presented as part of Task 4.



- Infrastructure sizing will be based on the recommendations in the Owner’s 2019 Master Plan and 2023 Addendum.
- No surveying or geotechnical services are included.
- Deliverable is a Preliminary Engineering Report. No AutoCAD drawing sets will be developed.

## Schedule

Engineer’s schedule for completing the Scope from Notice to Proceed (NTP) is presented in Table 1:

**Table 1 Project Schedule**

Task	Task Time
Draft PER Submittal	4 months from NTP
Final PER Submittal	3 weeks following the PER Review Meeting and receipt of all Owner comments to the Draft PER
Planning Data Review & Capital Project Analysis TM	5 months from NTP

## Compensation

Compensation to Engineer for the Scope of Services shall be for a lump sum value of \$378,900. A breakdown of fees by task and subtasks is presented in Table 2.

**Table 2 Project Fee**

Task	Labor (\$)	Expenses (\$)	Total (\$)
Subtotal: Task 1 – Shadybrook Lift Station	\$ 184,900	\$ 450	\$ 185,350
Subtotal: Task 2 – Shadybrook Gravity Sewers	\$ 61,800	\$ 275	\$ 62,075
Subtotal: Task 3 – Shadybrook Force Main	\$ 38,400	\$ 275	\$ 38,675
Subtotal: Task 4 – Project Review & Verification	\$ 92,400	\$ 400	\$ 92,800
Project Total	\$ 377,500	\$ 1,400	\$ 378,900

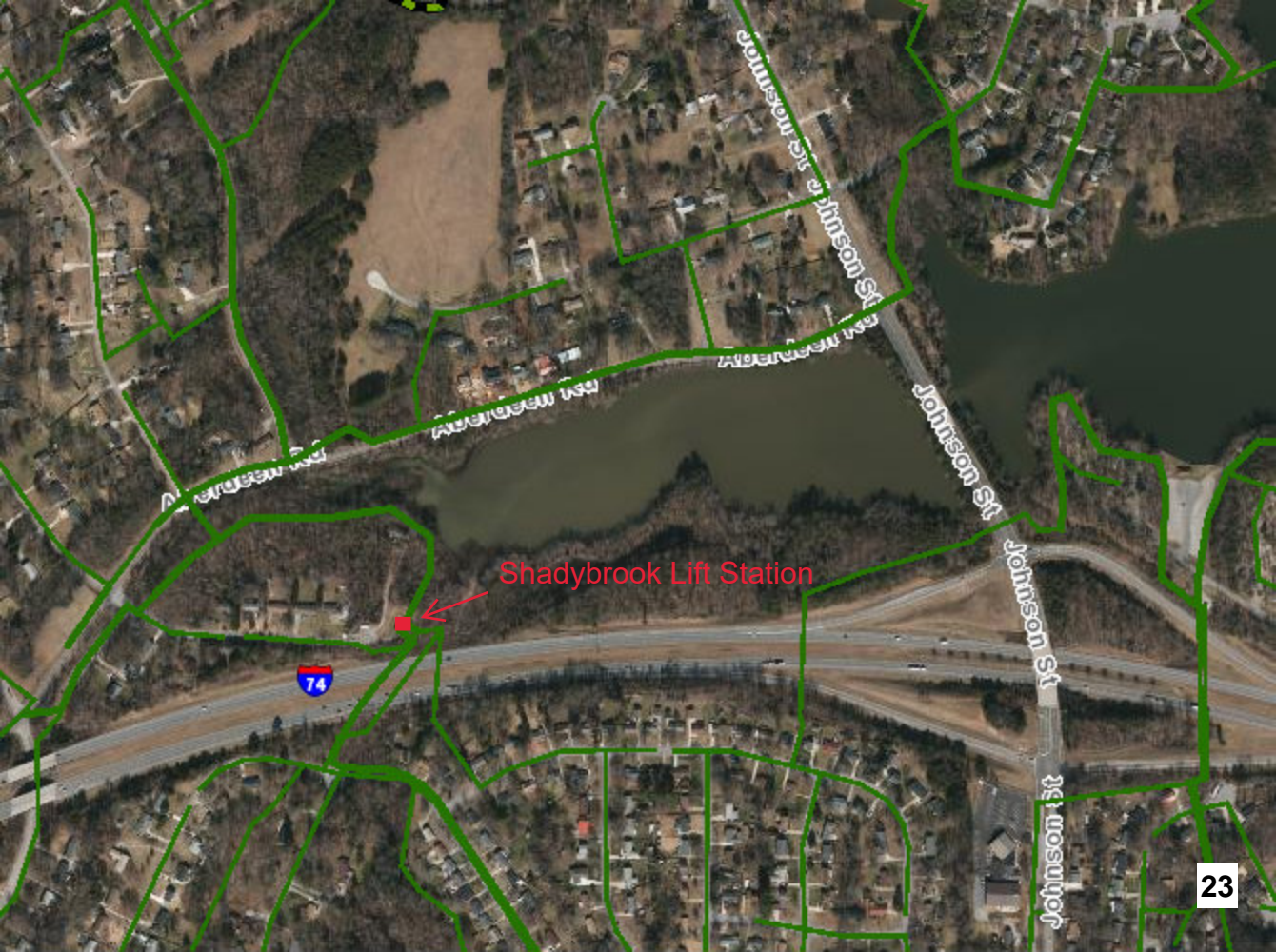

Shadybrook Lift Station

74



# City of High Point

Municipal Office Building  
211 S. Hamilton Street  
High Point, NC 27260

## Master

**File Number: 2024-032**

**File ID:** 2024-032

**Type:** Miscellaneous Item

**Status:** To Be Introduced

**Version:** 1

**Reference:**

**In Control:** Finance Committee

**File Created:** 01/24/2024

**File Name:**

**Final Action:**

**Title:** Consideration of a Task Order with HDR Engineering  
City Council is requested to approve a Task Order with HDR Engineering in the amount of \$344,400 for professional engineering services to upgrade filters 1-4 at the Ward Water Treatment Plant and authorize the appropriate City Official(s) to execute all necessary documents.

**Notes:**

**Sponsors:**

**Enactment Date:**

**Attachments:** Task Order - HDR Engineering- Ward Filter Rehabilitation Evaluation

**Enactment Number:**

**Contact Name:**

**Hearing Date:**

**Drafter Name:** dona.turner@highpointnc.gov

**Effective Date:**

## History of Legislative File

Ver- sion:	Acting Body:	Date:	Action:	Sent To:	Due Date:	Return Date:	Result:
---------------	--------------	-------	---------	----------	-----------	-----------------	---------



# CITY OF HIGH POINT

## AGENDA ITEM



<b>TITLE:</b> Ward WTP Filter Rehabilitation Evaluation – Professional Engineering Services HDR Engineering Inc.	
<b>FROM:</b> Robby Stone – Public Services Director Derrick Boone – Asst. Public Services Director	<b>MEETING DATE:</b> February 5, 2024
<b>PUBLIC HEARING:</b> N/A	<b>ADVERTISED DATE/BY:</b> Master Agreement - Task Order
<b>ATTACHMENTS:</b> Attachment A – Scope of Services	

**PURPOSE:** To approve a task order with HDR Engineering for the professional engineering services to upgrade filters 1-4 at the Ward Water Treatment Plant (WTP). The city has a master on-call agreement with HDR Engineering.

**BACKGROUND:** The City of High Point Public Services Department owns and operates the Frank L. Ward WTP, originally constructed in the early-1980s. The Ward Water Plant has both conventional filters, which were original to the plant construction, and a Greenleaf filter system, which was installed in the mid-1990s. The underdrain system for the conventional filters (1-4) was replaced in 2005 but has recently experienced challenges. The Public Services Department, with assistance from HDR, has evaluated filter underdrain options and selected a monolithic underdrain system. The purpose of this project is to develop design and construction documents so that the Public Services Department can obtain a contractor to complete the rehabilitation. In addition to replacing the underdrain system, the project covers the replacement of filter media and air scour piping, the replacement of valves and instrumentation, and coatings repair.

**BUDGET IMPACT:** Funds for this project are available in the FY 2023-2024 budget.

**RECOMENDATION/ACTION REQUESTED:** The Public Services Department recommends approval and asks for the Council to award this task order for professional engineering services to HDR Engineering Inc. in the amount of \$344,400 and authorize the appropriate City Official(s) to execute all necessary documents.



Ward WTP Filter Room



Ward WTP Pipe Gallery



# Supplemental Agreement

## Exhibit A

### Filter Rehabilitation Evaluation

#### Introduction

The City of High Point Public Services Department (City) owns and operates the Frank L. Ward Water Treatment Plant (WTP), originally constructed in the early-1980s. The WTP has both conventional filters, which were original to the plant construction, and a Greenleaf filter system, which was installed in the mid-1990s. The underdrain system for the conventional filters was replaced in 2005 but has recently experienced challenges. The City recently evaluated filter underdrain options and selected a monolithic underdrain system. The purpose of this project is to develop bid documents so that the City can obtain a contractor to complete the rehabilitation. In addition to replacing the underdrain system, the project covers the replacement of filter media and air scour piping, the replacement of valves and instrumentation, and coatings repair.

#### Scope of Services

The following Scope of Services (Scope) describes the services to be performed by HDR Engineering, Inc. of the Carolinas (Consultant). General assumptions include the following:

- All workshops will be held at the WTP unless otherwise noted. Meeting notes will be provided in an electronic format.
- Deliverables will be transmitted electronically and as hard copies (two full-sized sets and two half-sized sets).
- Comments from the City will be received in a compiled document. City review will take no longer than two weeks per document.
- City to pay for all permitting and agency review fees.
- City will provide contract agreement forms, general conditions, supplementary conditions, advertisement to bid, and instructions to bidders. Consultant will provide technical specifications including Division 01 General Requirements.
- No geotechnical services will be required.
- This Scope does not provide construction phase services; this may be provided in a separate proposal.

#### Task 1: Project Initiation and Management

Consultant will initiate this project by holding a Kickoff Meeting. This task also covers general functions required to maintain and track the project's schedule and budget.

#### CONSULTANT SERVICES:

- Project initiation, development of a schedule, and project documentation and filing.
- Coordination with the City on project status and key issues including monthly progress meetings when design workshops are not scheduled.
- General project accounting activities including invoicing.



- Overall project quality assurance and quality control (QA/QC).

**CITY RESPONSIBILITIES:**

- Attend progress meetings.

**ASSUMPTIONS:**

- Design and bid phase services are assumed to be eleven (11) months.
- Monthly progress meetings will be held during months when design workshops are not scheduled. Monthly progress meetings are assumed to last one hour and will be attended by Consultant's project manager and design manager. Up to six progress meetings are anticipated.
- Individual QC reviews are budgeted for under the design task.

**DELIVERABLES:**

- Project Kickoff Meeting Agenda and Notes.
- Notes from progress meetings.

**Task 2: Design and Permitting**

The purpose of this task is to progress and complete the design and permitting of the recommended upgrades identified in the Filter Rehabilitation Preliminary Engineering Report (PER). This includes a survey of the system; preparation of 60-percent, 90-percent, and 99-percent (Issued for Permitting) sets of drawings and specifications; coordination with permitting agencies and obtaining needed permitting before construction; and preparation of Issued for Bid drawings and specifications.

Design components are anticipated to include:

- Filter Rehabilitation – replacement of the filter media, underdrain system, air piping, and filter room floor drain.
- Pipe Gallery Rehabilitation – replacement of the valve systems (valve and actuator) and instrumentation associated with the filters, repair of pipe coatings, and replacement of chemical feed lines located within the interior of the pipe gallery.
- Replacement of BFV-4.
- Electrical and Instrumentation and control design associated with the filter and piping improvements identified above.

**CONSULTANT SERVICES:**

- Conduct a Terrestrial Light Image Detection and Ranging (LiDAR) survey of the filter basins and pipe gallery to develop a 3D model of the existing plant infrastructure. The 3D model will be used to develop design documents. The following structures will be included:
  - Filter basins.
  - Pipe gallery including the pump area.
- Prepare a technical memorandum identifying required permits and changes to the PER.



- Prepare 60-percent design documents and opinion of probable construction cost (OPCC). Conduct a 60-percent review workshop with the City and receive comments from the City.
- Prepare 90-percent design documents and OPCC. Conduct a 90-percent review workshop with the City and receive comments from the City.
- Coordinate with City and state permitting agencies to facilitate the approval of the project.
- Prepare 99-percent design documents for the North Carolina Department of Environmental Quality (NCDEQ) permitting review.
- Coordinate internally between disciplines in the preparation of design documents.
- Prepare and submit 100-percent design documents to include:
  - Digital copy of sealed design drawings and technical specifications.
  - Summary of work that includes a project description, contract duration, and agreed-upon amount for liquidated damages.
  - OPCC.
  - Bid Form in Word format.
  - List of contractors for the City to notify before advertising the project for bid.

**CITY RESPONSIBILITIES:**

- Review 60-percent, 90-percent, and 100-percent design drawings and technical specifications (as applicable) and provide comments.
- Participate in 60-percent and 90-percent review workshops.
- Coordinate and participate in meetings with planning and building departments.
- Prepare and provide front end (Division 0) contract documents, general and supplementary conditions, and select Division 1 specifications. Combine with Consultant's 100 percent technical specifications and sealed drawings for bidding.

**ASSUMPTIONS:**

- Design workshops are assumed to be three hours in length. Attendance for the workshops will include the project manager, design manager, and up to three additional attendees (e.g., electrical engineering, instrumentation engineer) as needed.
- No federal permits are assumed required for the work.
- Permitting reviews will consist of the following:
  - One City review consisting of all required agencies will be conducted at the 60-percent design phase.
  - One NCDEQ review will be conducted at 99-percent to gain permit approval for Authorization to Construct and Erosion and Sediment Control (if applicable).
- A City review of the 99-percent will not be conducted. Changes from the 99-percent design are intended to address comments from NCDEQ.
- The OPCC will be based on an AACE Class 3 estimate at 60% design and a Class 1 estimate at 90% and 100% design.

**DELIVERABLES:**

- Technical Memorandum covering permitting requirements and design changes or clarifications.



- 60-percent design: 60-percent design drawings, draft major equipment technical specifications, and OPCC.
- 90-percent design: design drawings, technical specifications, and OPCC.
- 99-percent design: permit-ready design drawings and technical specifications.
- 100-percent design: sealed bid drawings, compiled project specifications (Consultant's technical specifications and City's contract documents), and OPCC.
- Review Workshop Agenda and Notes.

### **Task 3: Bidding and Award**

The purpose of this task is to assist the City in bid phase services associated with the project.

#### **CONSULTANT SERVICES:**

- Attend a pre-bid conference and issue meeting notes.
- Assist the City in responding to questions received during bidding.
- Issue addenda as appropriate to clarify, correct, or change the bid documents.
- Attend and manage the bid opening.
- Assist the City in evaluating bids by preparing an engineering letter with bid tabulation sheets and a recommendation for contract award.
- Assist the City with assembling and awarding the construction contract.

#### **CITY RESPONSIBILITIES:**

- Advertise the project.
- Attend the pre-bid conference.
- Attend the bid opening.

#### **ASSUMPTIONS:**

- Pre-bid conference and bid opening will be attended by the project manager and design manager.
- Consultant will not provide dispute resolution services between the City and any bidders.
- Consultant will issue up to four addenda.
- Scope does not include project rebidding for any reason. Any Consultant efforts to support a rebid will require an amendment.

#### **DELIVERABLES:**

- Pre-Bid Conference Meeting Notes.
- Addenda.
- Bid Tabulation and Recommendation of Award Letter.
- Issued for Construction Contract Documents that conform to the contract documents with all addenda.

## **Schedule**

Consultant's schedule for completing the Scope from Notice to Proceed (NTP) is presented in Table 1:



**Table 1 Project Schedule**

Task	Task Time
Task 1 – Project Initiation and Management	9 months from NTP
Task 2 – Design and Permitting	60% Design – 12 weeks from NTP 90% Design – 8 weeks from 60% 99% Design – 4 weeks from 90% Design 100% Design – 2 weeks from NCDEQ Comments
Task 3 – Bidding and Award	2 months

## Compensation

Compensation to Consultant for the Scope of Services shall be for a lump sum value of \$344,400.00. A breakdown of fees by task and subtasks is presented in Table 2.

**Table 2 Project Fee**

Task	Labor (\$)	Expenses (\$)	Total (\$)
Subtotal: Task 1 – Project Initiation and Management	\$29,240.00	\$260.00	\$29,500.00
Subtotal: Task 2 – Design and Permitting	\$289,600.00	\$4000.00	\$293,600.00
Subtotal: Task 3 – Bidding and Award	\$20,500.00	\$800.00	\$21,300.00
Project Total	\$339,340.00	\$5,060.00	\$344,400.00





# City of High Point

Municipal Office Building  
211 S. Hamilton Street  
High Point, NC 27260

## Master

**File Number: 2024-033**

**File ID:** 2024-033

**Type:** Miscellaneous Item

**Status:** To Be Introduced

**Version:** 1

**Reference:**

**In Control:** Finance Committee

**File Created:** 01/25/2024

**File Name:**

**Final Action:**

**Title:** Consideration of Contract Amendment #1 to Machinex  
City Council is requested to approve contract amendment #1 to Machinex in the amount of \$196,820.00, increasing the amount of purchase order 112532 to \$1,496,820.00 and authorize the appropriate City Official(s) to execute all necessary documents.

**Notes:**

**Sponsors:**

**Enactment Date:**

**Attachments:** Contract - Machinex Amendment 1 MRF Baler

**Enactment Number:**

**Contact Name:**

**Hearing Date:**

**Drafter Name:** dona.turner@highpointnc.gov

**Effective Date:**

### History of Legislative File

Ver- sion:	Acting Body:	Date:	Action:	Sent To:	Due Date:	Return Date:	Result:

# CITY OF HIGH POINT

## AGENDA ITEM



<b>TITLE:</b> MRF Baler Upgrade- Amendment 1 Hazen	
<b>FROM:</b> Robby Stone – Public Services Director Melinda King – Asst. Public Services Director	<b>MEETING DATE:</b> February 5, 2024
<b>PUBLIC HEARING:</b> N/A	<b>ADVERTISED DATE/BY:</b> N/A
<b>ATTACHMENTS:</b> Attachment A – Amendment I Proposal Attachment B – Agreement for Goods Purchase and Installation	

**PURPOSE:** To request approval of contract amendment #1 to Machinex (original PO 112532) to incorporate additional equipment for operational and safety concerns.

**BACKGROUND:** The City of High Point opened the Material Recycling Facility in 1991 with the 1972 Mosely Dual Ram Baler. In 2015 the MRF purchased a Marathon Baler for redundancy and direct feed of fiber line. Staff is working on replacing the 1972 Mosely baler and relocating the Marathon Baler for redundancy during equipment breakdowns and maintenance needs. During final design, unforeseen operational concerns came to light regarding the new location; therefore, this change order will eliminate these concerns through the addition of specified equipment.

**BUDGET IMPACT:** Funds for this project are available in the FY 2023-2024 budget.

**RECOMMENDATION/ACTION REQUESTED:** The Public Services Department recommends approval of the amendment to Machinex in the amount of \$196,820.00, increasing the amount of purchase order 112532 to \$1,496,820.00.

1972 Mosely Baler



Baled Aluminum Cans



**PROJECT: City of High Point – Baler redundancy project**  
**CHANGE ORDER : 001**  
**FROM: Machinex**  
**TO: City of High Point**

**PROJECT NO.: 6278230714**  
**ORDER NO : 54618**  
**DATE : 2024/01/05**  
**REVISION : 0**

**DESCRIPTION OF CHANGES**

- |  |                     |
|--|---------------------|
| <b>1. Direct feed conveyor addition for new 2-rams baler</b> | <b>196,820.00\$</b> |
| New Roller Chain Conveyor with rubber belt cleted            |                     |
| Including all guards, supports and sidewalls                 |                     |
| Including e-stop pull-cord along flat portion of conveyor    |                     |
| Including control panel addition                             |                     |
| Including Freight to site                                    |                     |
| Including Mechanical and Electrical Installation             |                     |
| Including Commissioning and Startup                          |                     |

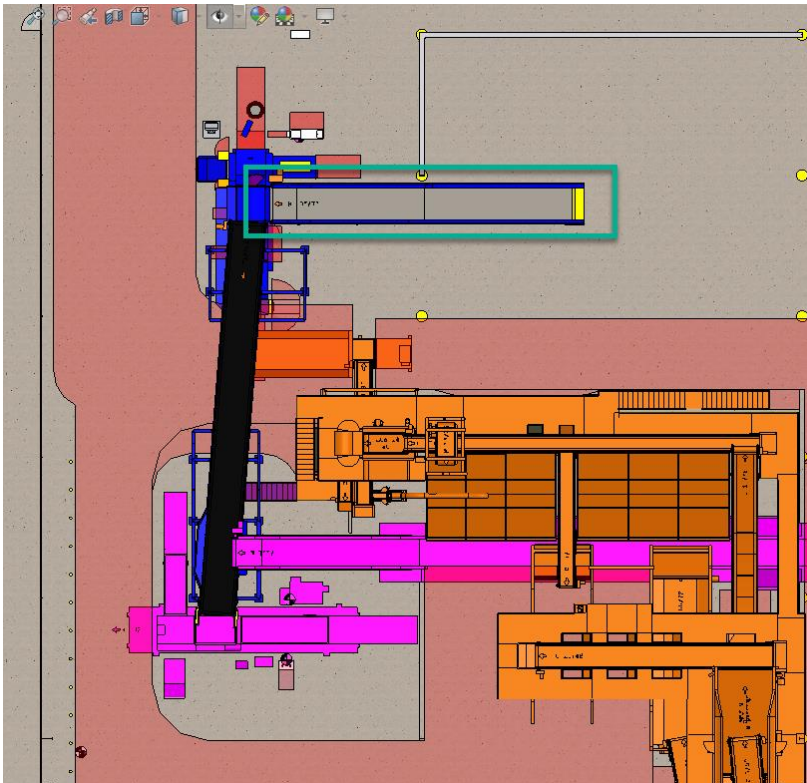

**Total: 196,820.00\$**

Original contract value : \$1,200,000.00 USD

Adjusted contract value after Changer order 001 : \$1,200,000.00 + 196,820.00\$ = 1,396,564.00\$ USD

**MACHINEX TECHNOLOGIES INC**

**PROJECT: City of High Point – Baler redundancy project**  
**CHANGE ORDER : 001**  
**FROM: Machinex**  
**TO: City of High Point**

**PROJECT NO.: 6278230714**  
**ORDER NO : 54618**  
**DATE : 2024/01/05**  
**REVISION : 0**

**PAYMENT TERMS**

Total amount shall be integrated to remaining invoices.

**CHANGE TO SCHEDULE**

Delivery of new equipment to site remain unchanged, date will be set in November 2024 after the Furniture Market as per request from the City of High Point.

---

*UNLESS MENTIONED IN THIS CHANGE ORDER, ALL PRECEDING CONTRACTUAL TERMS  
AND CONDITIONS STAY THE SAME*

---

ACCEPTED BY: \_\_\_\_\_  
Machinex  
(Authorized Signature)

DATE : \_\_\_\_\_

ACCEPTED BY: \_\_\_\_\_  
City of High Point  
(Authorized Signature)

DATE : \_\_\_\_\_

## AGREEMENT FOR GOODS PURCHASE

**THIS AGREEMENT FOR GOODS PURCHASE** (“**Agreement**”) is made on July 24, 2023 (the “**Effective Date**”), by and between the City of High Point, a North Carolina municipal corporation (the “**City**”), and Machinex Technologies, Inc., a(n) Delaware corporation (“**Seller**”). The City and Seller are at times collectively referred to hereinafter as the “**Parties**” or individually as a “**Party**”.

**WHEREAS**, Seller is in the business of selling goods that are of the type and nature of the Goods (as defined below); and

**WHEREAS**, the City desires to purchase the Goods from Seller, and Seller desires to sell the Goods to the City, all on the terms and conditions set forth herein.

**NOW, THEREFORE**, in consideration of the mutual covenants and agreements hereinafter set forth and for other good and valuable consideration, the receipt and sufficiency of which are hereby acknowledged, the Parties agree as follows:

1. Sale of Goods. Seller shall sell to the City, and the City shall purchase from Seller, the goods and any related services set forth on the proposal/quote attached as **Exhibit A** hereto (such goods and such related services, if any, the “**Goods**,” and such proposal/quote, the “**Quote**”) in the quantities, at the prices, and upon the terms and conditions set forth in this Agreement.

2. Delivery Date. Seller shall deliver the Goods in the quantities and on the date(s) specified in the Quote or as otherwise agreed in writing by the Parties (the “**Delivery Date**”). Timely delivery of the Goods is of the essence. If Seller fails to deliver the Goods in full on the Delivery Date, the City may terminate this Agreement immediately by providing written notice to Seller, and Seller shall indemnify the City against any losses, claims, damages, and reasonable costs and expenses directly attributable to Seller’s failure to deliver the Goods on the Delivery Date.

3. Quantity. Seller shall deliver the quantities of the Goods specified in the Quote. If Seller delivers more than the quantity of Goods specified in Quote, the City may reject all or any excess Goods. Any such rejected Goods shall be returned to Seller at Seller’s risk and expense. If the City does not reject the Goods and instead accepts the delivery of Goods at the increased quantity, the Price for the Goods shall be adjusted on a pro-rata basis.

4. Delivery Location. All Goods shall be delivered to the address specified in Quote (the “**Delivery Location**”) during the City’s normal business hours or as otherwise instructed by the City.

5. Shipping Terms. Delivery shall be made D.D.P. to the Delivery Location. Seller shall give written notice of shipment to the City when the Goods are delivered to a carrier for transportation. Seller shall provide the City all shipping documents, including the commercial

invoice, packing list, bill of lading, and any other documents necessary to release the Goods to the City within one (1) business day after Seller delivers the Goods to the transportation carrier. The Quote Number (as set forth on the Quote) must appear on all shipping documents, shipping labels, bills of lading, invoices, correspondence, and any other documents pertaining to this Agreement.

6. Title and Risk of Loss. Title passes to the City upon delivery of the Goods to the Delivery Location. Seller bears all risk of loss or damage to the Goods until delivery of the Goods to the Delivery Location and the City's (or its nominee's) acceptance of the Goods.

7. Packaging. Seller shall properly pack, mark, and ship the Goods as instructed by the City and otherwise in accordance with applicable law and industry standards and shall provide the City with shipment documentation showing the Quote Number, the quantity of Goods in shipment, the number of cartons or containers in shipment, Seller's name, the bill of lading number, the country of origin, and, if applicable to the Goods, current Safety Data Sheets in accordance with all applicable regulations.

8. Inspection and Rejection of Nonconforming Goods. The City has the right to inspect the Goods on or after the Delivery Date. Additionally, the City shall have the right to place an inspector in Seller's facility, which inspector shall be permitted to inspect any Goods (including any materials and components thereof) during the manufacturing process and prior to shipment. The City, at its sole option, may inspect all or a sample of the Goods, and may reject all or any portion of the Goods if it determines the Goods are nonconforming or defective. If the City rejects any portion of the Goods, the City has the right, effective upon written notice to Seller, to: (a) rescind this Agreement in its entirety; or (b) reject the Goods and require replacement of the rejected Goods. If the City requires replacement of the Goods, Seller shall, at its expense, as promptly as practicable but, in any event, within ten (10) calendar days, replace the nonconforming Goods and pay for all related expenses, including, but not limited to, transportation charges for the return of the defective goods and the delivery of replacement Goods. Any inspection or other action by the City under this Section shall not reduce or otherwise affect Seller's obligations under this Agreement, and the City shall have the right to conduct further inspections after Seller has carried out its remedial actions.

9. Price. The City shall purchase the Goods from Seller at the prices set forth in Quote, as it may be modified from time to time by agreement of the Parties (the "**Price**"). The Price includes all packaging costs, transportation costs to the Delivery Location, insurance, customs duties and fees, and applicable taxes. The Parties acknowledge and agree that the City is exempt from federal excise tax, but the City is not exempt from North Carolina's or the City's sales and use taxes. No increase in the Price is effective, whether due to increased material, labor, or transportation costs, or otherwise, without the prior written consent of the City.

10. Payment Terms. Seller shall issue an invoice to the City within ten (10) calendar days after the completion of delivery of the Goods, in accordance with the terms of the progress payments set forth in Seller's proposal/quote. The City shall pay all properly invoiced amounts

due to Seller within thirty (30) calendar days after the City's receipt of such invoice, except for any amounts disputed by the City in good faith. All payments hereunder must be in United States dollars. In the event of a payment dispute, the City shall deliver a written statement to Seller no later than fifteen (15) calendar days prior to the date payment is due on the disputed invoice, listing all disputed items. The Parties shall seek to resolve all such disputes expeditiously and in good faith. Seller shall continue performing its obligations under this Agreement notwithstanding any such dispute. Any early payment discount period shall commence on the later to occur of (a) the City's receipt of Seller's invoice for the Goods, and (b) the City's receipt of delivery of the Goods.

11. Setoff. Without prejudice to any other right or remedy it may have, the City reserves the right to set off at any time any amount owing to it by Seller against any amount payable by the City to Seller under this Agreement.

12. Warranties. Seller warrants to the City that (i) all Goods will (a) be free from any defects in workmanship, material, and design; (b) conform to applicable specifications and other requirements specified by the City; (c) be fit for their intended purpose and operate as intended; (d) be merchantable; (e) be free and clear of all liens, security interests, or other encumbrances; and (f) not infringe or misappropriate any third party's patent or other intellectual property rights; and (ii) the manufacturing, sale and delivery of the Goods pursuant to this Agreement will not violate any applicable local, state, or federal laws, rules, and regulations, including, without limitation, all such laws, rules and regulations prohibiting discrimination on the grounds of race, color, religion, sex, age, disability, national origin, or other protected classes. These warranties survive any delivery, inspection, acceptance, or payment of or for the Goods by the City. These warranties are cumulative and in addition to any other warranty provided by law or equity. Any applicable statute of limitations runs from the date of the City's discovery of the noncompliance of the Goods with the foregoing warranties. If the City gives Seller notice of noncompliance with this **Section 12**, Seller shall, at its own cost and expense, as promptly as practicable but, in any event, within ten (10) calendar days, replace or repair the defective or nonconforming Goods and pay for all related expenses, including, but not limited to, transportation charges for the return of the defective or nonconforming goods to Seller and the delivery of repaired or replacement Goods to the City.

13. Compliance with Law. Seller shall comply with all applicable local, state, and federal laws, regulations, ordinances, and rules. Seller has and shall maintain in effect all the licenses, permissions, authorizations, consents, and permits that it needs to carry out its obligations under this Agreement. Without limiting the generality of the foregoing, Seller represents, warrants, and certifies to the City that it currently complies with the requirements of Article 2 of Chapter 64 of the North Carolina General Statutes, and covenants that at all times during its performance under this Agreement, it will continue to comply with these requirements. Seller's breach of its representations, warranties, and/or covenants in this **Section 13** shall be deemed to be a material breach of this Agreement.



14. General Indemnification. Seller shall defend, indemnify, and hold harmless the City and its officers, directors, employees, agents, successors, and permitted assigns (each, an “**Indemnitee**”) from and against all losses, damages, liabilities, deficiencies, actions, judgments, interest, awards, penalties, fines, costs, or expenses of whatever kind, including reasonable attorneys’ fees and the cost of enforcing any right to indemnification hereunder and the cost of pursuing any insurance providers (collectively, “**Losses**”) arising out of or resulting from: (a) bodily injury, death of any person, or damage to real or tangible personal property resulting from the willful, fraudulent, or negligent acts or omissions of Seller or its employees, agents, and other personnel (collectively, “**Personnel**”); and (b) Seller’s breach of any representation, warranty, or obligation of Seller set forth in this Agreement.

15. Intellectual Property Indemnification. Seller shall defend, indemnify, and hold harmless the City and its officers, directors, employees, agents, successors, and permitted assigns from and against all Losses based on a claim that any of the Goods or the City’s receipt or use thereof infringes any intellectual property right of a third party; provided, however, that Seller shall have no obligations under this **Section 15** with respect to claims to the extent arising out of: (a) any instruction, information, designs, specifications, or other materials provided by the City in writing to Seller; (b) use of any Goods in combination with any materials or equipment not supplied to the City or specified by Seller in writing, if the infringement would have been avoided by the use of the Goods not so combined; or (c) any modifications or changes made to any Goods by or on behalf of any person other than Seller or its Personnel.

16. Insurance. For a period of five (5) years after the date of this Agreement, Seller shall, at its own expense, maintain and carry insurance in full force and effect with financially sound and reputable insurers that includes, but is not limited to, (i) commercial general liability (including product liability) with limits no less than \$1,000,000 for each occurrence and \$2,000,000 in the aggregate (the “**CGL Coverage**”); (ii) worker’s compensation with limits no less than the minimum amount required by applicable law; and (iii) commercial automobile liability with limits no less than \$2,000,000, combined single limit (the “**Commercial Auto Coverage**”). Upon the City’s request, Seller shall provide the City with certificates of insurance from Seller’s insurers evidencing the insurance coverages specified in this Agreement. Each certificate of insurance and the underlying policies for the CGL Coverage and the Commercial Auto Coverage shall name the City as an additional insured. All insurance policies required pursuant to this **Section 16** shall: (a) be issued by insurance companies reasonably acceptable to the City; (b) provide that such insurance companies give the City at least thirty (30) calendar days’ prior written notice of cancellation or non-renewal of policy coverage; provided that, prior to such cancellation, Seller shall have new insurance policies in place that meet the requirements of this **Section 16**; (c) waive any right of subrogation of the insurers against the City; and (d) provide that such insurance be primary insurance and any similar insurance in the name of and/or for the benefit of the City shall be excess and non-contributory. This **Section 16** shall not be construed in any manner as waiving, restricting, or limiting the liability of either Party for any obligations imposed

under this Agreement (including but not limited to, any provisions requiring a Party hereto to indemnify, defend, and hold the other Party harmless under this Agreement).

17. Termination. In addition to any remedies that may be provided under this Agreement, the City may terminate this Agreement with immediate effect upon written notice to Seller, either before or after the acceptance of the Goods, if Seller has not performed or complied with any of the terms and conditions of this Agreement, in whole or in part (a “**Termination for Seller’s Breach**”). In the event of a Termination for Seller’s Breach, the City may return, at Seller’s sole cost and expense, all or any portion of the Goods not received and accepted by the City prior to such termination. If Seller becomes insolvent, is generally unable to pay, or fails to pay, its debts as they become due, files a petition for bankruptcy or commences or has commenced against it proceedings relating to bankruptcy, receivership, reorganization, or assignment for the benefit of creditors, then the City may terminate this Agreement upon written notice to Seller. If the City terminates this Agreement for any reason, Seller’s sole and exclusive remedy is payment for the Goods received and accepted by the City prior to the termination.

18. Confidential Information. Seller agrees: (a) not to disclose or otherwise make available Confidential Information to any third party without the prior written consent of the City; provided, however, that Seller may disclose the Confidential Information to its Personnel and legal advisors who have a “need to know”, who have been apprised of this restriction, and who are themselves bound by nondisclosure obligations at least as restrictive as those set forth in this Section; (b) to use the Confidential Information only for the purposes of performing its obligations under this Agreement; and (c) to immediately notify the City in the event it becomes aware of any loss or disclosure of any of the Confidential Information. If Seller becomes legally compelled to disclose any Confidential Information, Seller shall provide: (x) prompt written notice of such requirement so that the City may seek, at its sole cost and expense, a protective order or other remedy; and (y) reasonable assistance, at the City’s sole cost and expense, in opposing such disclosure or seeking a protective order or other limitations on disclosure. If, after providing such notice and assistance as required herein, Seller remains required by law to disclose any Confidential Information, Seller shall disclose no more than that portion of the Confidential Information which, on the advice of Seller’s legal counsel, Seller is legally required to disclose. As used herein, “Confidential Information” means any information that is treated as confidential by the City, including but not limited to all non-public information about the City’s business affairs, products or services, intellectual property rights, trade secrets, third-party confidential information, and other sensitive or proprietary information, whether or not marked, designated, or otherwise identified as “confidential.” Confidential Information shall not include information that: (a) is already known to Seller without restriction on use or disclosure prior to receipt of such information from the City; (b) is or becomes generally known by the public other than by breach of this Agreement by, or other wrongful act of, Seller; (c) is developed by Seller independently of, and without reference to, any Confidential Information of the City; or (d) is received by Seller from a third party who is not under any obligation to the City to maintain the confidentiality of such information.

19. Entire Agreement; Conflicting Provisions. This Agreement, together with the portions of the Quote that are expressly cross-referenced herein and any other documents incorporated herein by reference, constitutes the sole and entire agreement of the Parties with respect to the subject matter contained herein, and supersedes all prior and contemporaneous understandings and agreements, both written and oral, with respect to such subject matter. In case of a conflict between the provisions of this Agreement and the provisions of any attachment or other document referenced by or incorporated into this Agreement, the provisions of this Agreement shall control and prevail. Any data, terms, conditions or similar provisions set forth in the Quote (other than such data, terms, conditions and similar provisions that are expressly contemplated by and cross-referenced in the body of this Agreement) shall not be deemed incorporated into this Agreement and shall be disregarded in their entirety. Any terms and conditions or similar provisions submitted by Seller on any invoice or other form shall not become a part of this Agreement unless agreed upon in a writing executed by a duly authorized representative of the City.

20. Survival. Subject to the limitations and other provisions of this Agreement: (a) the representations and warranties of the Parties contained herein shall survive the expiration or earlier termination of this Agreement; and (b) this **Section 20** and **Sections 10, 11, 12, 14, 15, 16** and **21** through **29**, inclusive, of this Agreement, as well as any other provision that, in order to give proper effect to its intent, should survive such expiration or termination, shall survive the expiration or earlier termination of this Agreement.

21. Notices. All notices, requests, consents, claims, demands, waivers, and other communications hereunder shall be in writing and shall be deemed to have been given (a) when delivered by hand (with written confirmation of receipt); or (b) on the third (3<sup>rd</sup>) calendar day after the date mailed, by certified or registered mail, return receipt requested, postage prepaid. Such communications must be sent to the respective Parties at the addresses indicated below (or at such other address for a Party as shall be specified in a notice given in accordance with this **Section 21**):

If to the City:

The City of High Point  
Purchasing Department  
P.O. Box 230  
High Point, NC 27261

If to Seller:

(See Seller's address for notices on the signature page hereof.)

22. Severability. The invalidity of one or more phrases, sentences, clauses, or sections in this Agreement shall not affect the validity of the remaining portions of this Agreement, so long as the material purpose of this Agreement can be determined and effectuated.

23. Amendments and Waivers. This Agreement may be amended, modified, or supplemented only by an agreement in writing signed by each Party hereto. No waiver by either Party of any of the provisions hereof shall be effective unless explicitly set forth in writing and signed by the Party so waiving. The City may at any time insist upon strict compliance with the terms and conditions of this Agreement, notwithstanding any previous custom, practice, or course of dealing to the contrary.

24. Cumulative Remedies. All rights and remedies provided in this Agreement are cumulative and not exclusive, and the exercise by either Party of any right or remedy does not preclude the exercise of any other rights or remedies that may now or subsequently be available at law, in equity, by statute, in any other agreement between the Parties, or otherwise. Notwithstanding the foregoing, the Parties intend that, if the City terminates this Agreement in accordance with **Section 17**, Seller's sole and exclusive remedy is the right to payment for the Goods received and accepted.

25. Successors and Assigns; Assignment. This Agreement is for the sole benefit of the Parties hereto and their respective successors and permitted assigns and nothing herein, express or implied, is intended to or shall confer upon any other person any legal or equitable right, benefit, or remedy of any nature whatsoever, under or by reason of this Agreement. Neither Party may assign, sublet, subcontract, or transfer any interest in this Agreement without the prior written consent of the other Party.

26. Governing Law; Jurisdiction. This Agreement and performance thereof shall be governed, interpreted, construed, and regulated by the laws of the State of North Carolina without giving effect to its principles regarding conflicts of laws. Any legal suit, action, or proceeding arising out of or related to this Agreement or the Services provided hereunder shall be instituted exclusively in the courts of North Carolina located in Guilford County, and each Party irrevocably submits to the exclusive jurisdiction of such courts in any such suit, action, or proceeding. Service of process, summons, notice, or other document by mail to such Party's address set forth herein shall be effective service of process for any suit, action, or other proceeding brought in any such court. To the extent permitted by applicable law, if any action, suit, or other legal or administrative proceeding is instituted or commenced by either Party hereto against the other Party arising out of or related to this Agreement, the prevailing Party shall be entitled to recover its reasonable attorneys' fees and court costs from the non-prevailing Party, in addition to any damages and costs otherwise awarded to the prevailing Party.

27. Counterparts. This Agreement may be signed in any number of counterparts, and all such counterparts together shall constitute one and the same instrument. A signed copy of this

Agreement delivered by facsimile, email, or other means of electronic transmission shall be deemed to have the same legal effect as delivery of an original signed copy of this Agreement.

28. Relationship of the Parties. The relationship between the Parties shall be that of independent contractors. Without limiting the generality of the foregoing, the Parties acknowledge and agree that Seller, its employees, subcontractors, and suppliers are not individually or collectively to be deemed an employee or employees of the City under any circumstances. Furthermore, nothing in this Agreement shall under any circumstances be construed to make the City and Seller joint venturers, partners, or parties to similar relationships with each other.

29. Disclosure. Seller agrees that it shall make no statements, press releases, or publicity releases concerning this Agreement or its subject matter or otherwise disclose or permit to be disclosed any of the data or other information obtained or furnished in compliance with this Agreement, or any particulars, thereof, without first notifying the City and securing its consent in writing.

30. No Debarment. Seller represents and warrants to the City that Seller is not currently (a) under sanction, exclusion, or investigation (civil or criminal by a federal or state enforcement, regulatory, administrative, or licensing agency) or otherwise ineligible for federal or state program participation, or (b) listed on North Carolina or any other state or federal debarment databases (e.g., Office of Inspector General and System for Award Management).

31. Representation of Authority. Any individual executing this Agreement on behalf of Seller hereby represents and warrants that he or she is, on the date he or she signs this Agreement, duly authorized by all necessary and appropriate action to execute this Agreement on behalf of Seller and does so with full legal authority.

*[SIGNATURES BEGIN ON THE NEXT PAGE]*

IN WITNESS WHEREOF, this Agreement is entered into by the Parties as of the Effective Date.

**The City:**

CITY OF HIGH POINT

*Tasha Logan Ford*

By: B43E07167B077FC08A53CE3CEFC4C9D3 contractworks

Name: Tasha Logan Ford

Title: City Manager

**Preaudit Certificate**

This instrument has been preaudited in the manner required by the Local Government Budget and Fiscal Control Act.

*Bobby Fitzjohn*

BB0A0449DDBEACDE4DF56386107C46DB contractworks

Bobby Fitzjohn, Finance Officer

**Seller:**

MACHINEX TECHNOLOGIES, INC.

By: Chris Hawn  
6D44E164C987C087C4352D4C655439C8 contractworks

Name: Chris Hawn

Title: CEO

*Seller's address for notices:*

716 Gallimore Dairy Rd.

High Point, NC 27265

Attn.: Rusty Angel

**EXHIBIT A**

**to**

**AGREEMENT FOR GOODS PURCHASE**

Quote

(See attached)



# M MACHINEX

*Experience Results*

**50** YEARS  
of EXPERIENCE  
& RESULTS



## SORTING TECHNOLOGIES EXPERT

Proposal #6822027-4

**City of High Point**

**Baler Replacement Project**



**TABLE OF CONTENTS**

1. INTRODUCTION ..... 3

2. PRICING CHART / MRF UPGRADES ..... 4

3. SYSTEM GUIDE LINES ..... 5

4. EQUIPMENT LIST ..... 7

5. EQUIPMENT DESCRIPTION ..... 8

    5.1 GENERAL DESIGN INFORMATION ..... 8

    5.2 MACHINEX TWO RAM BALER – MTR-195-TP – REGEN ..... 9

    5.3 SLIDER BED / SLIDER ROLLER CONVEYOR – TYPE CSRT ..... 11

6. ELECTRICAL INFORMATION ..... 12

    6.1 OPERATIONS PHILOSOPHY ..... 12

    6.2 INFO SWITCH GEAR ..... 13

7. LIMITED SCOPE OF SUPPLY ..... 14

8. TERMS AND CONDITIONS OF SALE ..... 18

9. SIGNATURES ..... 21

**APPENDICES**

APPENDIX A - LAYOUT ..... 22

## 1. INTRODUCTION

6/7/2023

Mr. Melanie Bruton  
**City of High Point**  
5875 Riverdale Drive  
Jamestown, NC  
27282

**SUBJECT: Baler Replacement Project**

We are pleased to submit our Proposal # 6822027-4 for your project featuring Machinex Technologies Inc. equipment.

More than 40 years ago, Machinex Technologies Inc. became the first company in Canada to design machinery for material recycling facilities. The company immediately established itself as a leader in designing profitable quality recycling sorting systems.

Today, Machinex Technologies Inc. is still a world leader in the industry, developing cutting edge sorting, waste management and recycling technology. Over the years, our expert staff have designed and installed turnkey projects in partnership with leading MRF operators in Canada, the United States, Oceania and Northern Europe.

More specifically for this project, Machinex Technologies Inc. has dedicated a tremendous amount of its engineering time and effort to offer the best solution at the best quality/price ratio for the industry and this based on the drawing MR-3183A-2 REV.6. Our technical solution includes numerous significant features which we believe deserve to be highlighted.

We hope that you will find that this proposal meets with your requirements. If you have any comments or questions, whatsoever, please do not hesitate to contact us.

Sincerely,

**Machinex Technologies Inc.**



---

**Brad Goins**  
Sales Project Director

**Machinex Technologies Inc.**



---

**Rusty Angel**  
Eastern Region Sales Manager

## 2. PRICING CHART / MRF UPGRADES

ITEM	PRICE [\$USD]**
<b>2.1 Upgrade #1 – Direct Baler Replacement</b>	<b>INCLUDED</b>
<p>Item description included</p> <ul style="list-style-type: none"> <li>→ Machinex Dual Ram Baler Model: MTR-195-TP</li> <li>→ Direct Baler Feed Hopper</li> <li>→ Freight to Site</li> <li>→ Dismantling of existing baler</li> <li>→ Mechanical Installation of new Machinex Baler</li> <li>→ Electrical Installation from (Baler Control Panel to Baler)</li> <li>→ Commissioning &amp; Startup</li> <li>→ Hydraulic Oil for Machinex Baler</li> </ul> <p>Not Included:</p> <ul style="list-style-type: none"> <li>→ Local Taxes &amp; Required Building Permits</li> <li>→ Any concrete work or steel plating under baler</li> <li>→ Modifications to Infeed Power from Building Switchgear</li> <li>→ Any Switchgear modifications</li> <li>→ Disposal of existing Mosley Baler</li> </ul>	
<b>2.2 Upgrade #2 - SS Baler Redundancy Package</b>	<b>INCLUDED</b>
<p>Item description including</p> <ul style="list-style-type: none"> <li>→ Add Reversing Conveyor (B-103) with option of feeding Machinex Baler or existing Marathon Baler</li> <li>→ Modifications to existing (B-101) Baler Reclaim Conveyor</li> <li>→ Relocation of Marathon Baler</li> <li>→ Additional Controls for new equipment</li> <li>→ Second Bunker Management Control Panel for Machinex Baler</li> <li>→ Additional Freight to Site</li> <li>→ Additional Mechanical &amp; Electrical Installation</li> </ul> <p>Not Included:</p> <ul style="list-style-type: none"> <li>→ Hydraulic Oil for Marathon Baler.</li> <li>→ Commissioning &amp; Startup of Marathon Baler in new location.</li> <li>→ Local Taxes &amp; Required Permits.</li> <li>→ Any concrete work or steel plating under balers.</li> <li>→ Modifications to Infeed Power from Building Switchgear.</li> <li>→ Any Switchgear modifications.</li> </ul>	
<b>GRAND TOTAL</b>	<b>\$1,200,000.00</b>

\*\*Taxes are not included in any of the given price\*\*

\*\*Prices are valid for standard Machinex Technologies Inc. colors: Blue RAL5010 and safety yellow RAL1037\*\*

### 3. SYSTEM GUIDE LINES

As requested, Machinex Technologies Inc. has put together this proposal to replace the existing Mosley Dual Ram Baler within the existing recycling facility. The base package will be a stand-alone baler with large hopper for loader direct access feed with an option of added additional conveyors within the existing single stream system so the baler can be used to bale different commodities stored within system bunkers.

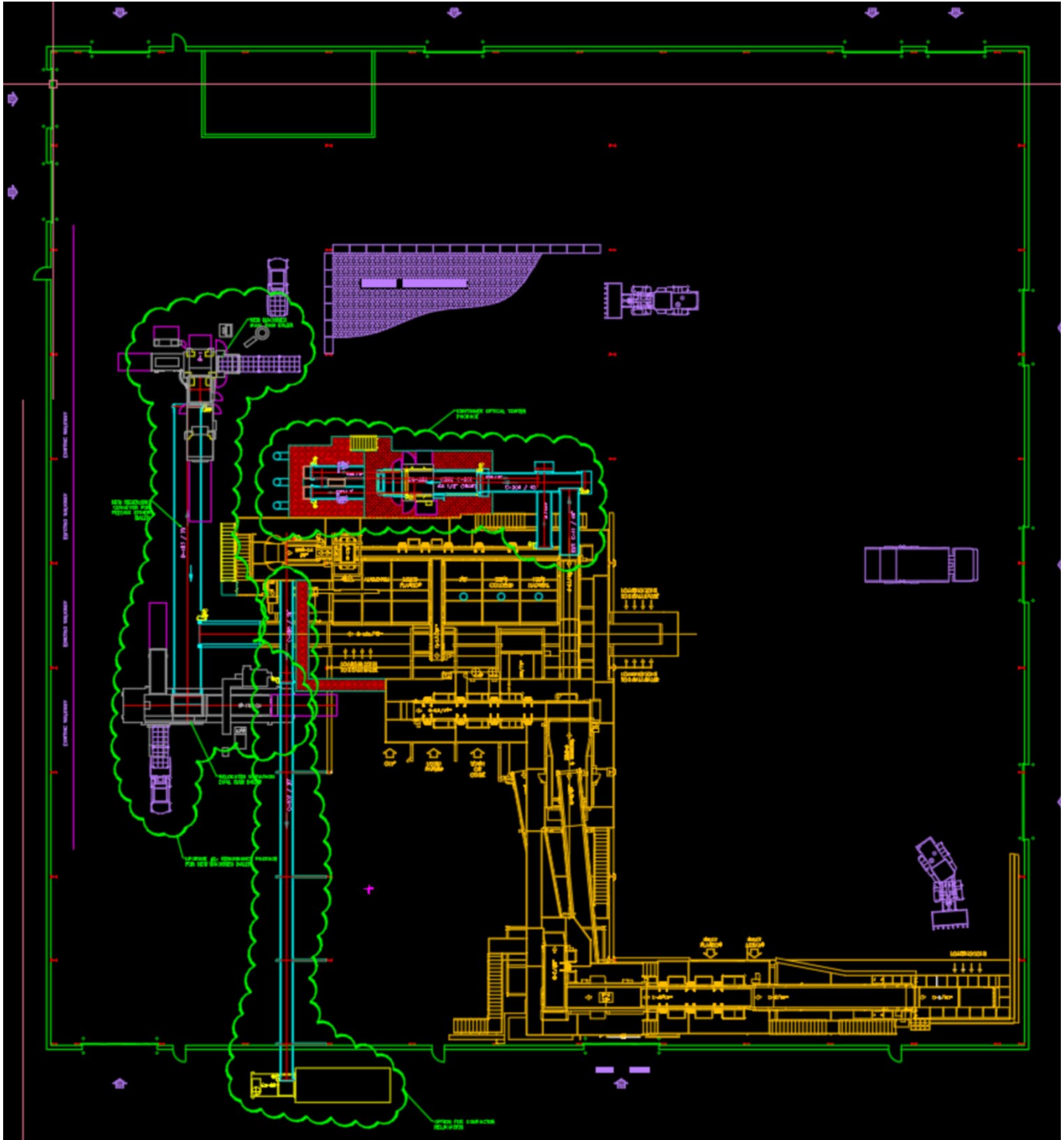

---

**SYSTEM FEATURES**

- System Integration and controls programming with new Machinex Baler
- Bunker Management System Integration with existing Machinex Control Panel
- Common Parts with other Machinex supplied equipment during MRF upgrade

---

**EQUIPMENT FEATURES**

- Baler Hinged Front Door for accessing ejection chamber & main ram easier
- Maintenance Platform for accessing hydraulic unit & drives
- Abrasive resistant Steel Bolt-On Liners for Easy Maintenance
  - Floor
  - Sidewalls
  - Gathering area
  - Compressing area
- Single Plate Frame Construction
- Adjustable Shear Blade
- HMI 15" Touchscreen

#### 4. EQUIPMENT LIST

**\*\*\*At this stage, the following equipment list should be considered as "preliminary / not for construction". The final information will be presented upon final engineering within our layout approval process. \*\*\***

##### 2.1 OPTION (TWO RAM BALER WITH DIRECT FEED)

ITEM #	DESCRIPTION	MODEL			WIDTH	LENGTH
			HP	VFD		
B-104	DUAL RAM MACHINEX BALER (Pump #1)	MTR-195-TP	75	-	---	---
"	DUAL RAM MACHINEX BALER (Pump #2)	"	75	-	---	---
"	DUAL RAM MACHINEX BALER (Recirculation pump)	"	5	-	---	---
"	DUAL RAM MACHINEX BALER (Fan cooler)	"	3	X	---	---
"	DUAL RAM MACHINEX BALER (Heater #1)	"	4	-	---	---
"	DUAL RAM MACHINEX BALER (Heater #2)	"	4	-	---	---
PLA-3	EXTRA LARGE BALER HOPPER		---	-	---	---

##### 2.2 OPTION (TWO RAM BALER WITH REDUNDANCY PACKAGE)

ITEM #	DESCRIPTION	MODEL			WIDTH	LENGTH
			HP	VFD		
B-101	EXTENTION TO EXISTING CONVEYOR	Z SHAPE	---	-	---	---
B-102	EXISTING MARATHON DUAL RAM BALER		---	-	---	---
B-103	BALER FEED	SLIDER BED	7.5	X	72"	71' 8"
B-104	DUAL RAM MACHINEX BALER (Pump #1)	MTR-195-TP	75	-	---	---
"	DUAL RAM MACHINEX BALER (Pump #2)	"	75	-	---	---
"	DUAL RAM MACHINEX BALER (Recirculation pump)	"	5	-	---	---
"	DUAL RAM MACHINEX BALER (Fan cooler)	"	3	X	---	---
"	DUAL RAM MACHINEX BALER (Heater #1)	"	4	-	---	---
"	DUAL RAM MACHINEX BALER (Heater #2)	"	4	-	---	---

## 5. EQUIPMENT DESCRIPTION

### 5.1 GENERAL DESIGN INFORMATION

---

#### Ancillary Features

Unless otherwise specified. These are some general Machinex Technologies Inc. key design features.

#### UNITS

- 1) Machinex Technologies Inc. equipment specifications are available in both imperial and metric, but this quote is in imperial units

#### SAFETY GUARDS AND OTHERS

- 2) All safety guards are bolt on type for ease of maintenance.
- 3) Protective guards are provided under an accessible height of 9'-0" [2.75m] on all equipment.
- 4) Roller baskets under conveyor provided at a height of 9'-0" [2.75m] and more in a working and/or walking zone.
- 5) Painted surface preparation includes chemical cleaning or sandblasting, prior to application of primer/paint.

#### DRIVES AND MOTORS

- 6) A complete list of motor power is available in Equipment List
- 7) Gear reducers and motors are helical in line shaft mount type, sized by application.
- 8) All motors are mounted on reducers and are PREMIUM efficiency type, 1.15 Service factor.

#### STRUCTURAL SUPPORTS

- 9) All equipment structural supports to be made of square tubing and/or structural steel.
- 10) All legs have boot adjustments. Each boot to be attached using "Wedge anchors" through 2 to 4 holes in each footpad.
- 11) Support bracings to be made of angle iron and/or structural steel.

#### TRANSFER PANELS

- 12) All transfer panels are made of formed steel plate. Transfer panels to be bolt on type for easy access to head shafts.
- 13) Appropriate adapter skirts or shields, chutes and transfer panels to be provided at all transfer points to ensure that all transitions are sufficiently enclosed to minimize spillage or dust emissions.



## 5.2 MACHINEX TWO RAM BALER – MTR-195-TP – REGEN

Multi-purpose two-ram baler to maximize density while reducing operating costs.

Features	Description	Additional information
<b>CONSTRUCTION</b>		
Baler frame	Gusseted and braced as required. Side walls are constructed from single plate	Construction for maximum strength and to minimize welded joints in high stress areas.
Floor and Sides Liners Plates	Bolted AR liners and strips Tongues and grooves design	Liners design allows an easy replacement without welding of the liners to the baler frame
Adjustable Main Shear Blade	Progressive "V" blade with 3D shaped teeth	Reduced wear on the floor Reduced demand on hydraulic system
Front Ram Hinged Door	At the end of the compression chamber	Allows main ram replacement without removing any hydraulic component (cylinder, hoses, etc...)
Automatic Wire Tier	Accent or L&P	<i>Optional: Smart Tier excluded unless noted otherwise</i>
Bale Separation Door	Ø5" bore cylinder	Maintains bale density until tying process while eliminating the risk of contamination
<b>OPTIONS</b>		
Power Unit Platform	Included	Easy maintenance access to power unit
<b>BALER DIMENSIONS</b>		
Overall Dimensions with Table (L x W)	27'-0" L x 24'-6" W	9'-11" H. at feed point
Feed Opening	6'-0" L x 4'-9" W	
Shipping Weight	78 000 lbs.	
<b>BALE SPECIFICATIONS</b>		
Size	38" to 48" x 30" x 60"	Adjustable Width
Volume	46.8 ft <sup>3</sup>	Approx. based on Width
<b>MAIN CYLINDER</b>		
Compressing Force	195 tons	Energy saving regeneration system
Cylinder Diameter	Ø10" bore	
Ram Face Pressure	232 PSI	
Stroke	120"	14" penetration to the back wall
<b>EJECT CYLINDER</b>		
Compressing Force	105.5 tons	
Cylinder Diameter	Ø8" bore	
Ram Face Pressure	228 PSI	
Stroke	82" (full eject)	

Features	Description	Additional information
<b>POWER AND HYDRAULIC</b>		
<b>Motors</b>	2 x 75 HP (55 kW) Soft Start	Both motors can run independently (redundancy)
<b>Pump</b>	Piston pump	Variable Flow and HP Limiter 230 gal/min
<b>Oil Reservoir</b>	800 gallons capacity On the baler to save footprint	Additional oil will be required after operating cylinders to fill hoses and cylinders.
<b>Operation Pressure</b>	5 000 PSI	
<b>Full Stroke time</b>	11 sec.	Dry Cycle
<b>Cooling</b>	Air-to-Oil	5 HP (3.7kW) Oil Cooler Pump Motor 1 HP (0.75kW) Cooler Fan Motor
<b>Oil</b>	ISO Grade 32 or 46	Depends on ambient temperature
<b>Filter</b>	5 Microns	Replaceable
<b>Oil Heater</b>	Submersion type (2 x 2kW)	<i>Optional: Excluded unless noted otherwise</i>
<b>CONTROLS AND SAFETY</b>		
<b>Level Sensors</b>	Three (3) level sensors	For precise control of baling Alarm on overfill of the baler hopper
<b>Control Valves</b>	Individual hydraulically actuated valves	Some are proportional, used to adjust speeds, accelerations and decelerations of main ram.
<b>Economizer</b>	Adjustable automatic motor sleep mode	Pump motors will shut off and only start again when material blocks photo sensors.
<b>Remote Troubleshooting</b>	Via an Ethernet connection	
<b>Safety</b>	Safety Door Switches	
<b>MAXIMUM TONNAGE CAPACITIES BASED ON MATERIAL *</b>		
<b>Plastics</b>	Up to 17 TPH	Density of 32lb/ft <sup>3</sup> . Bale Weight = 1600 Lbs.
<b>UBC</b>	Up to 16 TPH	Density of 25lb/ft <sup>3</sup> . Bale Weight = 1250 Lbs.
<b>Tin</b>	Up to 41 TPH	Density of 50lb/ft <sup>3</sup> . Bale Weight = 2500 Lbs.
<b>OCC</b>	Up to 22 TPH	Density of 36lb/ft <sup>3</sup> . Bale Weight = 1800 Lbs.
<b>NEWS + Mix Paper</b>	Up to 36 TPH	Density of 40lb/ft <sup>3</sup> . Bale Weight = 2000 Lbs.
<p>* Performance rates, bale weights and densities are subject to moisture content, infeed densities, feed rates, machine efficiency and other variables in baling process. Tonnages are evaluated at 100% efficiency (No waiting time). Based on an electric frequency of 60hz. 1 Tonne = 2000 lbs</p>		

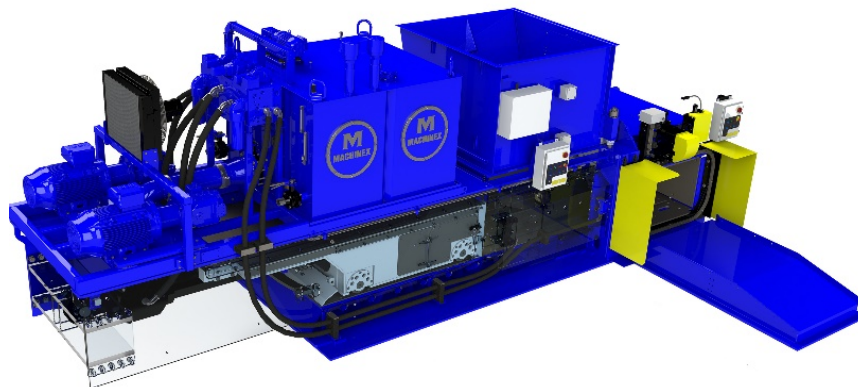

## 5.3 SLIDER BED / SLIDER ROLLER CONVEYOR – TYPE CSRT

All sorting conveyor and heavy-duty transfer conveyor

Features	Description	Additional information
<b>FRAME</b>		
<b>Construction</b>	Open frame 3/16" [5mm] thk.	Flat side conveyor
<b>Section length</b>	Maximum 12'-0" [3.657m]	Reinforced every 72" [1.828m]
<b>Connecting plates</b>	1/4" [6mm] thick	
<b>Conveyor bed or Carrying rollers</b> <i>(based on application)</i>	Steel plate 3/16" [5mm] slotted for self-cleaning or Ø5" [127mm] (steel-CEMA "C")	Roller with sealed bearings and slide in type brackets.
<b>Return rollers</b>	Ø5" [127mm] (steel-CEMA "C")	Roller with sealed bearings and slide in type brackets.
<b>Extension Panels</b>	Minimum 6" [152mm] height	12 gauge [2mm] steel plate
<b>BEARINGS, SHAFTS AND PULLEYS</b>		
<b>Tail bearing &amp; shaft</b>	Minimum Ø2 15/16" [75mm]	Pillow block bearing; Mounted on take-up mechanism; Taper hub bushings with keyways and set screws.
<b>Tail pulley</b>	Minimum Ø12" [305mm]	Winged, crowned and self-cleaning
<b>Head bearing &amp; shaft</b>	Minimum Ø2 15/16" [75mm]	Four (4) bolts flange bearing
<b>Head pulley</b>	Minimum Ø12" [305mm]	Crowned with 1/4" [6mm] lagging; Taper hub bushings with keyways and set screws.
<b>RUBBER BELT</b>		
<b>Belt</b>	Minimum 2 ply 220 PIW	One (1) piece with one mechanical joint
<b>Belt cover</b>	Top 3/16" [5mm] thick Low friction back	

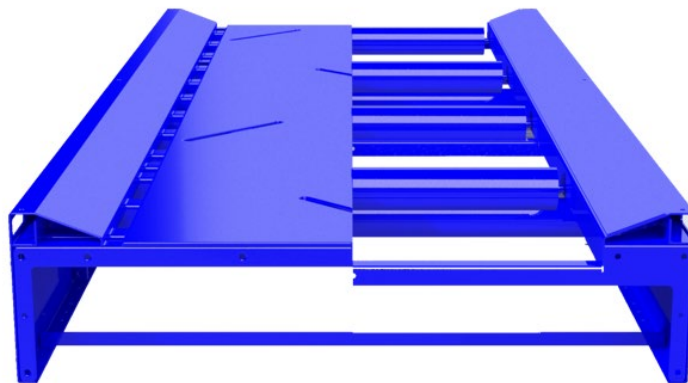

## 6. ELECTRICAL INFORMATION

### 6.1 OPERATIONS PHILOSOPHY

#### Infrastructure

The Local Control Panel (LCP) shall consist of base standing panels. Ventilation/cooling\*/heating will be provided according to the manufacturers' recommendations. The panel assembly will be approved according to local regulation (CSA; 22.2 #14-13, CSAus; UL508A, CE; IEC61439).

\*Cooling calculation are done with ambient temperature of 35 Celsius *degree*.  
If your project requirement differs, please advise your sales representative.

#### Safety Controller/Relay

The loop for safety components is done according to the manufacturers' recommendations and EN 954-1/ISO13849-1 standard is applied. It is possible to achieve high safety performance level through programming when having a safety controller, in which case zoning can be done with the connected circuits and proper design to facilitate maintenance\*\*. A risk assessment of the system will be done. Safety Performance Level of each function will be adjusted accordingly.

\*\*can be proposed as an option

#### Remote Access

Machinex uses eWON industrial VPN router to have remote access to the control panel and all its ethernet featured devices. The customer must bring, connect and commission the Internet access into Machinex control cabinet. The eWON is a full IP router featuring "Factory" LAN to "Machine" LAN routing functionalities with an embedded modem for use as a backup access to the "Machine" LAN.

**Advantages:** Firewall-friendly, Outbound connections only, Standard ports use: 443 (HTTPS) & 1194 (UDP),  
Compatible with customer LAN's Proxy

**Customer keeps control:** VPN access can be controlled with external key switch, Connection report

#### Motor Control

VFD, Soft/Start and motor starter with communication capabilities\*\*\* can be reset externally on minor faults. Thus, no need to open the panel to reset the Overload, prohibiting exposure of high voltage and reducing the downtime. Communication capabilities also came with amperage reading. With the amperage reading, a low and high current limit alarm can be set up. A low amp limit can be used to detect a loose or broken belt or a local disconnect let in OFF position. The high amp limit is usually set to detect an untracked belt or a blockage.

\*\*\*for components make/model/option, see Electrical Component

#### Emergency Stop

All emergency stop functions are designed according to ISO 13850:2008 4.1.3. Each operator/sorter workstation has an accessible emergency device (E-Stop or emergency pull cord) available (ISO 13850:2008 4.4.2). Emergency door switches have been installed on maintenance guards and access is determined by the risk assessment. The positioning of the e-stops is decided by several factors such as occupancy, equipment risk and egress. All frequent maintenance access doors have a safety door switch security detection installed.

**The E-Stops must only be activated in case of an emergency. Activation of an E-Stop during operation may lead to uncontrolled conditions in the system as all equipment are stopped disregarding of any sequence. Therefore, the reason for the activation of the E-Stop must be determined and an inspection of the system must be carried out before restart of the system.**

#### LOCK OUT / TAG OUT

Lock out / Tag out procedure is to be determined by the customer and shall be respected by everybody on site. Everything is in place to facilitate it, local motor isolator and MCC main disconnect switch allow multiple lock.

## 6.2 INFO SWITCH GEAR

2.2 PACKAGE - TWO RAM BALER DIRECT LOAD PACKAGE				
Description	Drop Tension (Volt)	Number of Phases	Frequency (Hz)	Panel protection (Main Breaker rating in Amp)
EXISTING - LCP3	460	3	60	15
EXISTING MARATHON DUAL RAM BALER	460	3	60	
B-104 DUAL RAM MACHINEX BALER	460	3	60	350

## 7. LIMITED SCOPE OF SUPPLY

Mechanical	Machinex Technologies Inc.	City of High Point
All necessary tools for the technicians	<input checked="" type="checkbox"/>	<input type="checkbox"/>
All necessary labor and travel expenses to install all the listed equipment and associated	<input checked="" type="checkbox"/>	<input type="checkbox"/>
Forklift, Crane and Scissors lift	<input checked="" type="checkbox"/>	<input type="checkbox"/>
Start-up	<input checked="" type="checkbox"/>	<input type="checkbox"/>
Touch-up	<input checked="" type="checkbox"/>	<input type="checkbox"/>
Any misfit will be corrected in a timely fashion by the installation crew always in contact with the project manager.	<input checked="" type="checkbox"/>	<input type="checkbox"/>
Any refurbishing or new components on existing equipment	<input type="checkbox"/>	<input checked="" type="checkbox"/>
Dismantling of the existing equipment	<input type="checkbox"/>	<input checked="" type="checkbox"/>
Any form of dismantling or general cleaning of the area	<input type="checkbox"/>	<input checked="" type="checkbox"/>
Disposal of used equipment, if any	<input type="checkbox"/>	<input checked="" type="checkbox"/>
Any (new or existing) equipment cleaning, if necessary	<input type="checkbox"/>	<input checked="" type="checkbox"/>
Access to facilities for Machinex Technologies Inc. employee	<input type="checkbox"/>	<input checked="" type="checkbox"/>
Sprinkler work	<input type="checkbox"/>	<input checked="" type="checkbox"/>
Filling pits if required	<input type="checkbox"/>	<input checked="" type="checkbox"/>
Any misfit resulting of building or other work not included will be managed together under a change order agreement and additional charges may apply.	<input type="checkbox"/>	<input checked="" type="checkbox"/>

Building	Machinex Technologies Inc.	City of High Point
Any building modifications as such but not limited to: building extension, pits, wall openings, ceiling and trusses.	<input type="checkbox"/>	<input checked="" type="checkbox"/>
Any fire protection system (Sprinklers) neither in the building nor any additional sprinklers underneath the proposed equipment (if required).	<input type="checkbox"/>	<input checked="" type="checkbox"/>
Any Enclosure or cabin modifications or opening	<input type="checkbox"/>	<input checked="" type="checkbox"/>
Any concrete blocks	<input type="checkbox"/>	<input checked="" type="checkbox"/>
Concrete slab calculations, modifications if needed (in time, equipment loads would be provided)	<input type="checkbox"/>	<input checked="" type="checkbox"/>
Any enclosure or cabin modifications or opening	<input type="checkbox"/>	<input checked="" type="checkbox"/>
Any dust collection/suppression system. It also excludes all dust collection/suppression system supporting structure, fixing or hoods to our equipment.	<input type="checkbox"/>	<input checked="" type="checkbox"/>

Electrical Wiring	Machinex Technologies Inc.	City of High Point
<b>Infeed wiring:</b> Bringing or removing main power from the electrical room / switchgear to new Machinex Technologies Inc. control panels (460/3/60): LCP's Optical Units, Air Compressors, Balers, Compactors, Shredders, or any other control panel. Machinex Technologies Inc. will advise on the location & the level of each load drops required once project is awarded.	<input type="checkbox"/>	<input checked="" type="checkbox"/>
<b>Infeed wiring:</b> Modifying/removing main power from the main switchgear (Building Service Entrance) to new Machinex Technologies Inc. control panels, (460/3/60): LCP's Optical Units, Air Compressors, Balers, Compactors, Shredders, or any other control panel. Machinex Technologies Inc. will advise on the location & the level of each load drops required once project is awarded.	<input type="checkbox"/>	<input checked="" type="checkbox"/>
<b>Switchgear update:</b> Any modification to the existing switchgear for the additional load.	<input type="checkbox"/>	<input checked="" type="checkbox"/>
Power Factor Correction/Compensation system	<input type="checkbox"/>	<input checked="" type="checkbox"/>
RAMS	<input type="checkbox"/>	<input checked="" type="checkbox"/>
Harmonic Correction/compensation system	<input type="checkbox"/>	<input checked="" type="checkbox"/>
<b>Field wiring:</b> Bringing power and control wiring (MC Cables) from control panels to each field devices (Motor, E-Stop, Photocell, etc.) that will meet local codes.	<input checked="" type="checkbox"/>	<input type="checkbox"/>
Local Motor Disconnect for new Motor added	<input checked="" type="checkbox"/>	<input type="checkbox"/>
Electrical installation guidelines, support and quality control	<input checked="" type="checkbox"/>	<input type="checkbox"/>
Dismantling wiring from equipment being removed to existing control panel.	<input checked="" type="checkbox"/>	<input type="checkbox"/>
Light and emergency lighting under the platform	<input type="checkbox"/>	<input checked="" type="checkbox"/>
Light and emergency lighting in maintenance area	<input type="checkbox"/>	<input checked="" type="checkbox"/>
Any addition/modification of maintenance outlet	<input type="checkbox"/>	<input checked="" type="checkbox"/>
Any modification to the fire alarm system	<input type="checkbox"/>	<input checked="" type="checkbox"/>
Internet connection of at least 5 Mbps and up to 50 Gb of data bandwidth per month (10 Mbps 50 Gb if SamurAI unit in the system) to the main Control Panel. See Operation Philosophy for remote connection detailed.	<input type="checkbox"/>	<input checked="" type="checkbox"/>
Ethernet connection from main Machinex control panel to Machinex provided equipment	<input checked="" type="checkbox"/>	<input type="checkbox"/>

Electrical Control	Machinex Technologies Inc.	City of High Point
<b>New Control Panel:</b> for controlling newly supplied equipment. New Control Panel will comply with local regulation. See Operation Philosophy section for more details.	<input checked="" type="checkbox"/>	<input type="checkbox"/>
Electrical control drawing for newly supplied equipment	<input checked="" type="checkbox"/>	<input type="checkbox"/>
<b>Any new field devices:</b> E-Stop, Safety door switch, Photocell, Trapped key, Emergency-Stop pull cord, Time delay pull cord, limit switch, zero-speed switch, push button station, etc.	<input checked="" type="checkbox"/>	<input type="checkbox"/>
<b>Modification of existing Control Panels:</b> Integration/Interconnection with new Machinex Technologies Inc. control panel, including but not limited to: PLC, HMI, Machine Safety, Electrical Drawing, Scada, mobile device, etc. It is Machinex Technologies Inc. duty to advise the customer that is control might not achieve today's safety standards and requirement and propose a solution. Under the OSHA law, the employers have a responsibility to provide a safe workplace with standards, rules and regulations.	<input checked="" type="checkbox"/>	<input type="checkbox"/>
Upgrading safety performance for existing equipment or control panel	<input type="checkbox"/>	<input checked="" type="checkbox"/>
Any control upgrade for the existing control panel	<input type="checkbox"/>	<input checked="" type="checkbox"/>
Replacing defective parts in existing control system if required	<input type="checkbox"/>	<input checked="" type="checkbox"/>
Integration / interlock with existing system control panels → Modification to the hardware of the existing system control panels → Modification of the existing PLC / program / HMI	<input type="checkbox"/>	<input checked="" type="checkbox"/>
Any modification/addition of video system (CCTV)	<input type="checkbox"/>	<input checked="" type="checkbox"/>
Any furniture for the control room (computer/furniture)	<input type="checkbox"/>	<input checked="" type="checkbox"/>
Any complete Lock-out/Tag-out procedure	<input type="checkbox"/>	<input checked="" type="checkbox"/>
Any Arc Flash Study	<input type="checkbox"/>	<input checked="" type="checkbox"/>

Commissioning and Testing	Machinex Technologies Inc.	City of High Point
Labor costs associated with cleaning and maintenance of plant during commissioning testing period. These tasks need to be done by the Employer which is part of the essential operational learning curve.	<input type="checkbox"/>	<input checked="" type="checkbox"/>
Supply of sufficient baling wire and other consumables (fuel, oil, lubricants, water, chemical, etc.) items throughout the commissioning testing period. It is the Employer's responsibility to forecast and order a sufficient amount of in-feed material and any necessary consumables. Machinex Technologies Inc. could however bring on-site some consumables to avoid any emergency situations.	<input type="checkbox"/>	<input checked="" type="checkbox"/>
Any fee for the Independent testing agency.	<input type="checkbox"/>	<input checked="" type="checkbox"/>



Miscellaneous	Machinex Technologies Inc.	City of High Point
Any rolling stocks	<input type="checkbox"/>	<input checked="" type="checkbox"/>
Any containers or bins	<input type="checkbox"/>	<input checked="" type="checkbox"/>
Any security fences	<input type="checkbox"/>	<input checked="" type="checkbox"/>
Double emergency pull-cords	<input type="checkbox"/>	<input checked="" type="checkbox"/>
Life lines on conveyors	<input type="checkbox"/>	<input checked="" type="checkbox"/>
Any fee for the Independent CE marking audit inspection	<input type="checkbox"/>	<input checked="" type="checkbox"/>
Pre-Start Health & Safety Review	<input type="checkbox"/>	<input checked="" type="checkbox"/>
Any local Electrical Inspection fees	<input type="checkbox"/>	<input checked="" type="checkbox"/>
Any local pressure vessel inspection fees	<input type="checkbox"/>	<input checked="" type="checkbox"/>
Any insurance costs	<input type="checkbox"/>	<input checked="" type="checkbox"/>
Any as build drawings after install	<input type="checkbox"/>	<input checked="" type="checkbox"/>
Any cleaning of equipment after install (snow, mud)	<input type="checkbox"/>	<input checked="" type="checkbox"/>
Hydraulic Oil	<input type="checkbox"/>	<input checked="" type="checkbox"/>
Local EPA permits, i.e. EPA & Planning and/or construction	<input type="checkbox"/>	<input checked="" type="checkbox"/>
Seismic engineering (if applicable)	<input type="checkbox"/>	<input checked="" type="checkbox"/>
Building permits (if applicable)	<input type="checkbox"/>	<input checked="" type="checkbox"/>
RAMS	<input type="checkbox"/>	<input checked="" type="checkbox"/>
Compressor & piping	<input type="checkbox"/>	<input checked="" type="checkbox"/>
The provision of all necessary safety equipment (fire blanket, eyes washer station, extinguishers, etc.)	<input type="checkbox"/>	<input checked="" type="checkbox"/>

#### General notes

- Price reflects the use of non-union labor for equipment installation (Machinex Technologies Inc. crew). We reserve the right to modify pricing should the use of union labor be required or if prevailing wage apply
- Machinex Technologies Inc. request to be included as named insured to the Buyer's Builder's Risk Insurance, while on site performing installation, start-up, commissioning, and punch-list as specified within our term and conditions.

## 8. TERMS AND CONDITIONS OF SALE

All products shall be supplied by Machinex Technologies Inc. and accepted by the buyer in accordance with the following Terms and Conditions of Sale:

### PRICES

Our prices for the technical equipment are valid for 5 business days.

Prices are subject to change after that period. Clerical and stenographic errors are subject to correction.

Note: Actual fluctuation in steel cost, components shortage and currency exchange may cause price increase in short term on some equipment. Final review of the proposal will be completed at time of final design

Our prices exclude payment of all taxes, if applicable.

### TERMS OF PAYMENT

- 25% with order;
- 30% upon 25% manufacturing completion;
- 35% prior shipment;
- 10% due upon start-up not to exceed 30 days from arrival on site;

### NOTES

Machinex Technologies Inc. will remain the owner of all the supplied equipment (or any part or portion thereof) until final and complete payment. The buyer shall do all things necessary to perfect and maintain such right and title to Machinex Technologies Inc..

In the case where the buyer would not respect the terms of payment and that Machinex Technologies Inc. would have to take back the equipment, the buyer accepts that Machinex Technologies Inc. will keep, as compensation, all sums already paid by the buyer.

### INFORMATION

We have assumed that the customer, without any delay, will give Machinex Technologies Inc. information about all circumstances that may have an effect on the time schedule.

### INSTALLATION

The installation is included in the price

### FREIGHT

The freight is included in the price

**D.D.P. (Incoterms 2020):** High Point, NC

\*\*Any special freight requirements for specific roads or thaw periods is subjected to a price review.

### WARRANTY

All new equipment is covered with a warranty of 12 months (2200 hours) whichever comes first against manufacturer's equipment defaults (material) while in normal use.

The warranty period starts from the date of delivery

The warranty will lapse if the equipment is repaired or altered by personnel that has not been authorized by Machinex Technologies Inc. to carry out repairs, or if operation and maintenance instructions for the equipment have not been followed and approved.

Machinex Technologies Inc. or anyone having participated to the delivery or the installation of the equipment cannot be held responsible for loss or damages of any kind, or from any cause, to any person or property of any person, or for loss of revenue or profit, or for any other special, incidental or consequential damages.

Any parts or equipment which Machinex Technologies Inc. supplies but does not manufacture shall be subject only to the warranties of Machinex Technologies Inc. vendors to the extent Machinex Technologies Inc. can enforce such warranties.

The warranty covers replacement parts only and excludes labor and consequential damages.

This warranty does not cover expendable parts, maintenance (alignment, adjustments etc.), wear or impact on Machinex Technologies Inc. products, including but not limited to, lubrication grease, oils, hydraulic connectors, gaskets and seals and any other items that may show evidence of negligence use or overloading, abuse, accident, improper maintenance, storage, improper use or unauthorized alterations.

Buyer shall notify Machinex Technologies Inc. in writing within fifteen (15) days of discovery, within the warranty period, of any alleged defect and permit Machinex Technologies Inc. and/or its representatives to make such investigation, examination and tests deemed appropriate. Upon request from Machinex Technologies Inc., the buyer shall return the alleged defective product to Machinex Technologies Inc. factory for examination and testing. If Machinex Technologies Inc. determines that the product is defective, and provided that the warranty of quality applies, Machinex Technologies Inc. will either repair or replace such product with a similar item of Machinex Technologies Inc.'s manufacture, F.O.B. Machinex Technologies Inc.'s factory of allow buyer credit for an amount equal to the one invoiced for the said product. The replacement, repair or development of a defective part shall not give rise to any extension of the terms initially fixed for the warranty period.

Any action for breach of warranty or other action under this agreement must be commenced within one (1) year after such cause of action arises.

In regard to equipment that is sold as "used" and "as is", if applicable, Machinex Technologies Inc. declines all warranties, whether expressed or implied, and assumes no responsibility nor authorizes any person to assume any liability on its behalf in regard to the sale of said equipment.

If Machinex Technologies Inc. is not integrating the equipment, new or used, Machinex Technologies Inc. declines any responsibility regarding security related to the equipment being sold as "used". Since the buyer is responsible for the integration of this equipment, the Buyer has the responsibility to ensure compliance with regulations. The Buyer is entirely responsible for the security of this equipment during operation and in accordance with regulation standards.

THIS LIMITED WARRANTY IS IN LIEU OF ALL OTHER WARRANTIES, EXPRESSED OR IMPLIED, INCLUDING ANY IMPLIED WARRANTY OF MERCHANTABILITY OR FITNESS.

**INSURANCE**

The Owner (customer) is responsible for the insurance of the equipment after arrival on site, as well as during unloading from trucks or containers. All other insurance for the installation period is under customer's responsibility.

The Owner shall obtain and maintain Builder's Risk Property Insurance including Work and Products, upon the entire Project for the full replacement cost and including Sales Taxes at the time of loss. This insurance shall include as named insured the Owner, Contractor, and Subcontractors. The policy shall insure against direct risk of physical loss or damage including flood or other water damage, earthquake, act of terrorism, transit, off premises storage, boiler & machinery. The coverage shall be maintained continuously until 10 Days after the date of the final certificate for payment (or after the date of start-up testing and commissioning). In case of loss, the Owner is responsible for the insurance deductibles. Maximum deductible for all risk perils is \$10,000 except flood and earthquake, which shall be \$25,000 and \$100,000 respectively, in this contract currency.

Until the Purchase Price has been paid in full, the Owner shall have the obligation to maintain all the Equipment sold and delivered properly insured against theft and loss or damage by fire or other cause with a reputable and solvent insurance company, and to provide the Vendor with the evidence of such insurance coverage. Such policy shall name the Vendor as loss payee. In the event of a theft, loss or damage to the Equipment sold before the Purchase Price has been paid in full, the Vendor shall have the right to collect any insurance proceeds that may be payable, up to the extent of its interest.

Evidence of coverage as shown in a certificate of Insurance is to be presented to Machinex Technologies Inc. before beginning of work. In addition, the policy or policies will have to be endorsed with an undertaking by the Insurer to provide Machinex Technologies Inc. with not less than Thirty (30) days advance written notice of cancellation, change or amendment restricting coverage.

**DELIVERY**

Deliveries are scheduled for with reception of a purchase order and down payment, clarification of required technical information, resolution of commercial issues, and customer approval of drawings when required. In the event where the customer must delay the equipment delivery, storage fees may apply.

Machinex Technologies Inc. shall not be liable for delays in delivery or failure to manufacture due to force majeure or causes beyond its reasonable control such as Acts of God, acts of omissions of the buyer, acts or omissions of civil or military authority, priorities, fire, strikes, floods, epidemics, quarantines, restrictions, riot, war, act of terrorism, delays in transportation, transportation vehicle/vessel shortages and inability to perform due to inability to obtain necessary labor, materials or manufacturing facilities. In the events of any delay such as above described, the date of delivery shall be extended for a period equal to the time lost by such delay.

Without limiting the generality of the terms used in the paragraph above, the Vendor shall not be liable for any failure to deliver if the failure is caused by an event of Force Majeure. In those circumstances, the delivery date shall automatically be extended for a period equivalent to the delay caused by the Force Majeure event.

The Owner shall do whatever is required in order to allow the Vendor to have free access to the Facility for the purpose of installing the Equipment sold in the Facility. The Owner shall promptly notify

Vendor of all circumstances that may have an effect on the schedule and/or the price of the project.

During the process of completing the Vendor's Scope of Work, should the Vendor encounter or be notified of conditions outside of their control, it is Vendor's responsibility to provide Written Notification to Owner of any possible delays or extended costs to the Owner. These conditions could include a) any physical condition on the Site which is affecting Vendor's ability to deliver or complete the work on schedule, or b) any Supply Chain variation condition (such as the electronic / electrical components shortage) which is significantly affecting Vendor's ability to manufacture, deliver, or install the goods at the contracted price and/or and the planned time.

Written notification from Vendor to Owner shall include the following information: a) condition encountered, b) steps the Vendor is taking or proposing to overcome condition, and c) estimates of the cost and/or delay effect on the Scope of Work that the Vendor will incur.

**CANCELLATION**

No order may be canceled by the buyer except upon written notice to Machinex Technologies Inc. and upon payment to Machinex Technologies Inc. of all costs incurred by it arising out of, or in connection with the order, determined on a basis consistently observed by Machinex Technologies Inc. and in accordance with sound accounting principles. Machinex Technologies Inc. shall have the right to cancel any order or to refuse to deliver or to delay shipment in the event buyer fails to submit payments when due or perform any other obligations of buyer.

**SPECIAL CLAUSE**

Machinex Technologies Inc. reserves the possibility to make any modifications or adjustments to the design or equipment shown on drawing MR-3183A-2 REV.6. Although the layout will remain the same, any adjustments such as but not limited to: the horsepower of motors, conveyor frame, conveyor type, safety features or others that can improve or standardize the equipment shown on the previously mentioned drawing and specification detail is under Machinex Technologies Inc. discretion.

In a circumstance where the buyer purchases in whole or in part an equipment, that is to be utilized in this system, directly from another manufacturer than Machinex Technologies Inc. the buyer is responsible for all costs as well as the management related to the equipment's integration, unless otherwise specified in this proposal. These costs may include, but are not limited to, the items listed in the section "Limited Scope of Supply" such as: delivery charges and unloading, insurances, warranties, performance guarantees, integration, mechanical and electrical installation (wiring and controls), civil work (building, permits, safety and environmental standards), start-up, testing and any other cost related to these including redoing these if necessary.

In the case where Machinex Technologies Inc. commits to such equipment's integration, certain information will be required throughout the project and dates will be assigned that such information needs to be provided by the buyer and remains under the buyer's responsibility and management. If such information is not supplied within the expected timeline, additional costs will be charged to the buyer.

Whether the equipment is being integrated by the buyer or Machinex Technologies Inc., any delays and additional costs in the project that are related to that equipment such as but not limited to: communication with supplier to validate equipment integration

protocol, communication and control protocol, performances and mechanical / physical equipment integration are solely the responsibility of the buyer. Any additional cost related to these delays will be at the Buyer's expense.

---

**MODIFICATIONS**

No waivers or modification of any of the foregoing Terms and Conditions of Sale shall be valid unless made in writing and signed by both parties. The failure of Machinex Technologies Inc. to enforce any right it possesses under the foregoing Terms and Conditions of Sale shall not constitute a waiver thereof or establish a custom. In the event any Terms and Conditions of any submitted by buyer to Machinex Technologies Inc. shall conflict with any Terms and conditions herein, the Terms and Conditions set forth herein shall govern and prevail.

In the event any other agreement between the Owner and Vendor regarding the Project shall be in conflict with any of the terms and conditions stated in this document, the terms and conditions set forth in this document shall govern and prevail.

---

**DISPUTE RESOLUTION**

Any dispute which arises in the course of this agreement shall be definitively settled by means of arbitration and to the exclusion of courts of law. However, in order to minimize the costs, there shall be only one arbitrator, and the arbitration proceedings and all documentation shall be in the English language. The arbitrator's decision will be final, without appeal and will bind upon the parties.

## 9. SIGNATURES

Machinex Technologies Inc.

City of High Point

6/7/2023

\_\_\_\_\_

\_\_\_\_\_

\_\_\_\_\_

\_\_\_\_\_

Name  
Title

Date

Name  
Title

Date

Machinex Technologies Inc.

City of High Point

6/7/2023

\_\_\_\_\_

\_\_\_\_\_

\_\_\_\_\_

\_\_\_\_\_

Name  
Title

Date

Name  
Title

Date

# *APPENDIX A - LAYOUT*

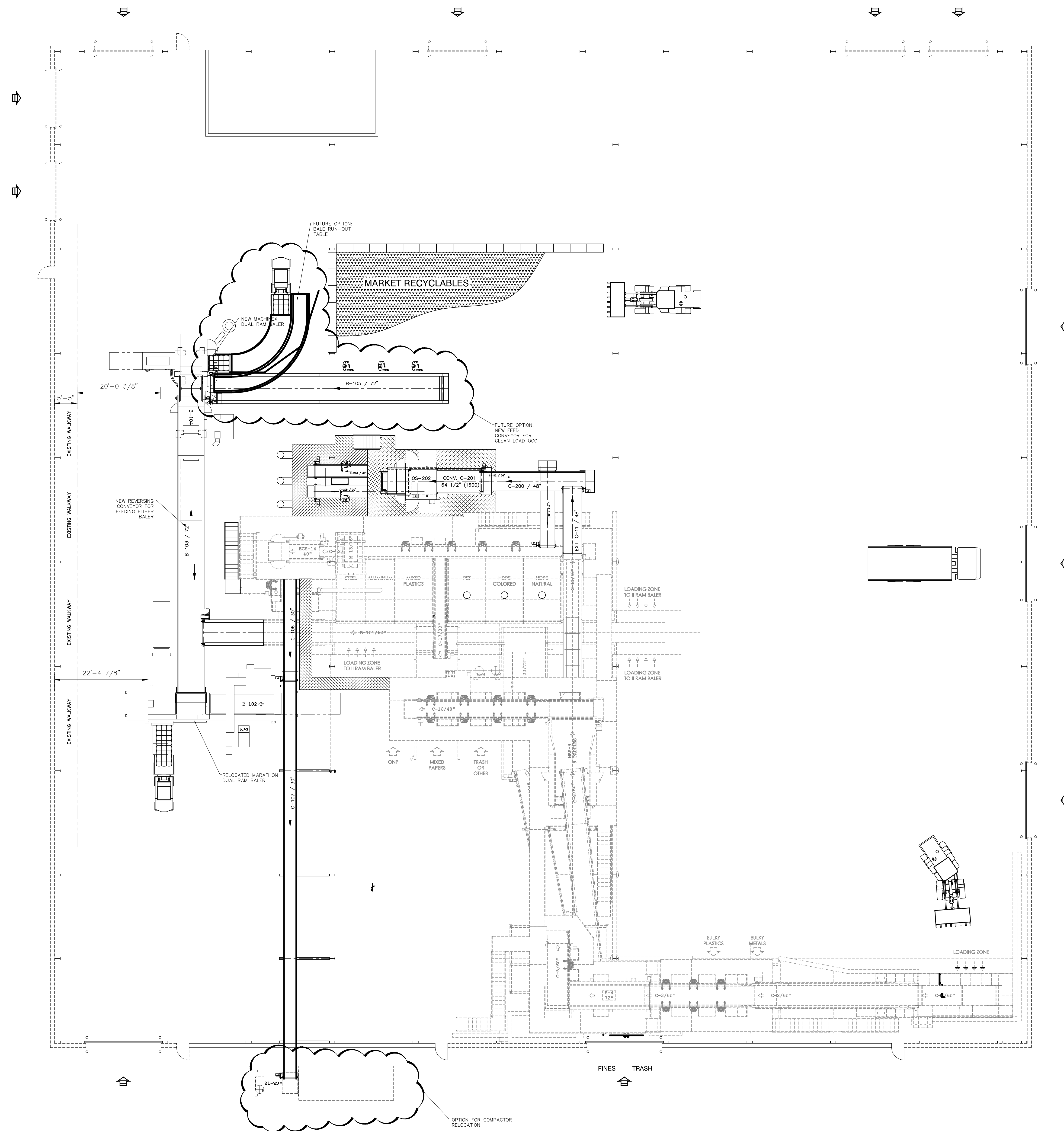

DWG. No.	TITLE	No.	DESCRIPTION	DATE	BY	No.	DESCRIPTION	DATE	BY
	REFERENCE DRAWINGS								

No.	DESCRIPTION	DATE	BY
1	RELEASED FOR REVIEW	2016-09-23	DBG
0	RELEASED FOR REVIEW	2014-03-05	SPT

STAMP	STAMP
-------	-------

SCALE :	3/32" = 12"
DESIGNED :	DBG DATE : 9/9/2022
DRAWN :	DBG DATE : 9/9/2022
CHECKED :	DBG DATE : 9/9/2022
APPROVED :	DATE :

DESIGNED BY :  
MACHINEX INDUSTRIES INC.  
2121, Olivier Street  
Riverside, Quebec, Canada, G6L 3G9  
Phone: (819) 362-3281  
Fax: (819) 362-2280 E-Mail: sales@machinex.ca

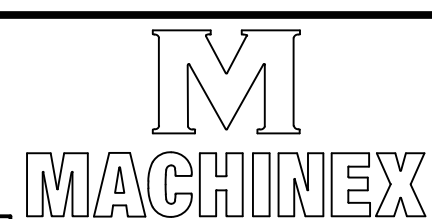

CLIENT :	CITY OF HIGH POINT 5875 Riverdale Dr Jamestown, NC 27282
PROJECT NO :	6822027-0
DRAWING NO :	MR-3183A-1

MATERIAL RECOVERY FACILITY BALER REPLACEMENT PROJECT UPGRADE #2 GENERAL LAYOUT
MACHINEX
6 REV. 4

THIS DRAWING IS THE PROPERTY OF MACHINEX INDUSTRIES INC. IT MAY NOT BE COPIED, REPRODUCED OR TRANSMITTED/RENDERED ACCESSIBLE IN ANY MANNER WITHOUT THE WRITTEN CONSENT OF MACHINEX INDUSTRIES INC. EQUIPMENT SHOWN ON THIS DRAWING HAS BEEN RELEASED FOR MANUFACTURING. ANY CHANGE WILL RESULT IN A PRICE ADJUSTMENT. 2022 DELIVERY IN SOUTHEAST



# City of High Point

Municipal Office Building  
211 S. Hamilton Street  
High Point, NC 27260

## Master

**File Number: 2024-030**

**File ID:** 2024-030

**Type:** Miscellaneous Item

**Status:** To Be Introduced

**Version:** 1

**Reference:**

**In Control:** Finance Committee

**File Created:** 01/23/2024

**File Name:**

**Final Action:**

**Title:** Consideration of a Nonprofit Organization Agreement with High Point Market Authority  
City Council is requested to approve a Nonprofit Organization Agreement with High Point Market Authority and authorize the appropriate City Officials to execute all necessary documents.

**Notes:**

**Sponsors:**

**Enactment Date:**

**Attachments:** HPMA Nonprofit Agreement

**Enactment Number:**

**Contact Name:**

**Hearing Date:**

**Drafter Name:** sandra.keeney@highpointnc.gov

**Effective Date:**

### History of Legislative File

Ver- sion:	Acting Body:	Date:	Action:	Sent To:	Due Date:	Return Date:	Result:



# CITY OF HIGH POINT

## AGENDA ITEM



<b>TITLE:</b> Nonprofit Agreement – High Point Market Authority – Showroom District Improvements	
<b>FROM:</b> Damon C. Dequenne, Assistant City Manager	<b>MEETING DATE:</b> February 5, 2024
<b>PUBLIC HEARING:</b> N/A	<b>ADVERTISED DATE/BY:</b> N/A
<b>ATTACHMENTS:</b> Nonprofit Organization Agreement	

### PURPOSE:

To consider execution of an agreement with High Point Market Authority (HPMA) for the design and construction of improvements in the Showroom District.

### BACKGROUND:

Included in the adoption of this year’s state budget was \$9 million dollars for capital funding of infrastructure and other improvements for the HPMA. The funding is spread over two years, \$4 million in the current fiscal year and \$5 million in the next. HPMA and the city desire to enter into an agreement where the city would administer the public improvements and contribute in kind services and a not to exceed amount of \$3.4 million toward the same.

The improvements consist of, but are not limited to, the following.

- Additional pedestrian level lighting for safety and aesthetics
- Security camera integration to enhance security
- Upgrades and maintenance to transportation terminal
- On street staffed debris removal during Pre-Market and Market
- Graffiti removal and abatement
- General beautification efforts (hanging baskets, benches, decorative cans, and planters)
- Burying power lines, installing traffic and fiber optic facilities, sidewalks, water and sewer and stormwater utilities on portions of South Main Street, West Russell Avenue, and South Wrenn Street

### BUDGET IMPACT:

Funding for the City obligations will be included in the proposed 2024/2025 Electric (approximately \$3.1 million) budget and available pending approval of the budget by City Council. The Transportation (approximately \$300,000) improvements will be funded with existing capital appropriations.

### RECOMENDATION /ACTION REQUESTED:

The City Council is requested to approve the Nonprofit Organization Agreement with High Point Market Authority and to authorize the appropriate city officials to execute all necessary documents.

## NONPROFIT ORGANIZATION AGREEMENT

**THIS NONPROFIT ORGANIZATION AGREEMENT** (“Agreement”) is made this \_\_\_\_ day of February, 2024 (the “Effective Date”), by and between the **CITY OF HIGH POINT**, a North Carolina municipal corporation (the “City”), and **HIGH POINT INTERNATIONAL HOME FURNISHINGS MARKET AUTHORITY CORPORATION**, a North Carolina nonprofit corporation (“Organization”). The City and the Organization are at times collectively referred to hereinafter as the “Parties” or individually as a “Party”.

**WHEREAS**, the Organization is organized and operated exclusively for exempt purposes as set forth in section 501(c)(6) of the Internal Revenue Code; and

**WHEREAS**, the Organization has secured state funding to provide certain public improvements as further defined below (hereinafter the “Improvements”) generally located within the Core City Showroom District of the City, as shown on **Exhibit A** attached hereto and incorporated herein by reference; and

**WHEREAS**, the City and the Organization desire to install and agree that the Improvements consist of the following:

- Additional pedestrian level lighting for safety and aesthetics
- Security camera integration to enhance security
- Upgrades and maintenance to transportation terminal
- On street staffed debris removal during the Organization’s Pre-Market and Market
- Graffiti removal and abatement
- General beautification efforts (hanging baskets, benches, decorative trash cans, and planters)
- Burying power lines, installing conduit, and other traffic and fiber optic facilities, sidewalks, water and sewer and stormwater utilities on portions of South Main Street, West Russell Avenue, and South Wrenn Street, as depicted on **Exhibit B** attached hereto and incorporated herein by reference; and

**WHEREAS**, the estimated cost of the Improvements, including but not limited to, engineering, labor, and materials, is in excess of nine million dollars (\$9,000,000.00); and

**WHEREAS**, the City and the Organization agree to share in the cost of the Improvements as more particularly described below, in order to promote uniform street improvements and facilitate pedestrian transportation while enhancing appearances and condition of the area;

**WHEREAS**, the Parties agree that sharing of costs allows the construction of the Improvements to be more economical and efficient; and

**WHEREAS**, the City has determined that the Organization is capable of providing the Improvements, it is in the public’s interest for the Organization to do so, and the Improvements serve a public purpose that the City is authorized by law to engage in.

**NOW, THEREFORE**, the City and the Organization, in consideration of their mutual covenants, hereby agree as follows:

## **SECTION I. RESPONSIBILITIES OF THE ORGANIZATION**

A. Construction of the Improvements. The Organization will work with the City for the construction of the Improvements, accepting responsibilities as follows:

1. The Organization will facilitate and coordinate with private property owners regarding impacts of the Improvements to their property.
2. The Organization will manage and complete any non-public improvements.

B. Sharing of Costs. The Organization agrees to share in the costs of the Improvements in order to promote uniform street improvements and facilitate pedestrian transportation while enhancing appearances and condition of the area.

C. Reimbursement to City. The Organization agrees to reimburse the City for expenses related to the Improvements monthly, but no later than thirty (30) days after invoice. Invoices will be accompanied by adequate justification and documentation as agreed to by the Parties.

D. Easements and Permits. The Organization agrees to execute all necessary documents to facilitate the completion of the Improvements, including without limitation, facilitating any and all necessary easements naming City as the grantee without costs.

E. Representations and Warranties. The Organization represents and warrants that it has no knowledge of the presence of any hazardous or toxic materials, compounds, or chemicals, on or around the property related to the Improvements that might interfere with or make unsafe the Improvements under this Agreement.

F. Compliance with Law and Non-Discrimination. The Organization shall comply with all Federal, State and local laws and ordinances applicable to the Improvements. The Organization shall at all times comply with all safety and health regulations, standards and codes applicable to the Improvements. The Organization shall not discriminate in any manner on the basis of race, color, gender, national origin, age, disability, religion, sexual orientation, gender identity/expression, familial status, or veteran status.

G. E-Verify. The Organization certifies that it currently complies with the requirements of Article 2 of Chapter 64 of the North Carolina General Statutes, and that at all times during the term of this Agreement, it will continue to comply with these requirements. The Organization also certifies that it will require that all of its subcontractors that provide any of the Improvements comply with the requirements of Article 2 of Chapter 64 of the North Carolina General Statutes. Violation of this section shall be deemed a material breach of this Agreement.

H. No Debarment. The Organization represents and warrants to the City that it is not currently (a) under sanction, exclusion, or investigation (civil or criminal by a federal or state enforcement, regulatory, administrative, or licensing agency) or otherwise ineligible for federal or state program participation, or (b) listed on North Carolina or any other state or federal debarment databases (e.g., Office of Inspector General and System for Award Management).

## **SECTION II. RESPONSIBILITIES OF THE CITY**

A. Construction of the Improvements. The City will work with the Organization for the construction of the Improvements, accepting responsibilities as follows:

1. The City shall act as primary agent for design and construction of the Improvements.
2. The City shall provide contract oversight and management for the design and construction of the Improvements.
3. The City shall coordinate with North Carolina Department of Transportation regarding improvements or encroachments in their right-of-way.
4. The City shall provide documentation and invoices, as necessary, to the Organization for compliance with the North Carolina Department of Commerce funding requirements.
5. The City shall be responsible for all future maintenance of the Improvements within the public right-of-way.

B. Sharing of Costs. The City agrees to share in the costs of the Improvements in order to promote uniform street improvements and facilitate pedestrian transportation while enhancing appearances and condition of the area. The City contributions to the Improvements will consist of “in kind” services and monetary funding in an amount not to exceed three million four hundred thousand (\$3,400,000.00) toward the burying of electric power lines and upgrades/maintenance to transportation terminal.

## **SECTION III. RELATIONSHIP BETWEEN THE PARTIES**

A. Independent Contractor. The Organization is an independent contractor. The Organization, its employees, subcontractors, suppliers and consultants are not, individually or collectively, to be deemed an employee or employees of the City under any circumstances. This Agreement shall not under any circumstances be construed to make the City and the Organization joint venturers, partners or parties to similar relationships with each other.

## **SECTION IV. TERM AND TERMINATION**

A. Term. The term of this Agreement will commence on the Effective Date and continue until the Improvements are completed.

B. Termination for Breach. This Agreement may be terminated by either Party upon notice to the other Party in the event of the other Party's material breach of this Agreement; provided that no termination for material breach may be effected unless the breaching Party fails to cure such breach within thirty (30) calendar days following its receipt of notice of such breach from the non-breaching Party.

## SECTION V. DISCLAIMER, INDEMNIFICATION, AND INSURANCE

A. Disclaimer of Liability. Under no circumstances will the City be liable for the Organization's provision of the Improvements.

B. General Indemnification. To the fullest extent allowed by law, the Organization shall indemnify, hold harmless and defend the City, its employees, agents and representatives, from and against any and all claims or damages directly or indirectly arising out of or resulting from or related to the Organization's provision of the Improvements.

C. Insurance. The Organization shall, at its own cost and expense, procure and maintain, and cause all subcontractors and suppliers to procure and maintain, in full force and effect during the entire term of this Agreement, commercially reasonable insurance coverage.

D. The City as Additional Insured. The City, its employees, agents and representatives shall be listed as an additional insured on all insurance coverages procured by the Organization pursuant to this Agreement.

E. Certificates of Insurance. The Organization shall, prior to the Organization's provision of the Improvements, provide properly completed certificates of insurance showing the existence and effective dates of all coverages.

## SECTION VI. MISCELLANEOUS

A. Governing Law and Venue. This Agreement and performance thereof shall be governed, interpreted, construed, and regulated by the laws of the State of North Carolina without giving effect to its principles regarding conflicts of laws. Any legal suit, action, or proceeding arising out of or related to this Agreement shall be instituted exclusively in the courts of North Carolina located in Guilford County, and each Party irrevocably submits to the exclusive jurisdiction of such courts in any such suit, action, or proceeding. Service of process, summons, notice, or other document by mail to such Party's address set forth herein shall be effective service of process for any suit, action, or other proceeding brought in any such court. To the extent permitted by applicable law, if any action, suit, or other legal or administrative proceeding is instituted or commenced by either Party hereto against the other Party arising out of or related to this Agreement, the prevailing Party shall be entitled to recover its reasonable attorneys' fees and court costs from the non-prevailing Party, in addition to any damages and costs otherwise awarded to the prevailing Party.

B. Entire Agreement, Conflicting Provisions. This Agreement, together with all Exhibits and any other documents incorporated herein by reference, constitutes the sole and

entire agreement of the Parties with respect to the subject matter contained herein, and supersedes all prior and contemporaneous understandings and agreements, both written and oral, with respect to such subject matter. In case of a conflict between the provisions of this Agreement and the provisions of any attachment or other document referenced by or incorporated into this Agreement, the provisions of this Agreement shall control and prevail.

C. Successors and Assigns. This Agreement is for the sole benefit of the Parties hereto and their respective successors and permitted assigns and nothing herein, express or implied, is intended to or shall confer upon any other person any legal or equitable right, benefit, or remedy of any nature whatsoever, under or by reason of this Agreement. Neither Party may assign, sublet, subcontract, or transfer any interest in this Agreement without the prior written consent of the other Party.

D. Captions and Headings. The captions and headings contained in this Agreement are for convenience and reference only, and do not define, describe, extend, or limit the scope or intent of this Agreement or the scope or intent of any provision contained herein.

E. Severability. The invalidity of one or more phrases, sentences, clauses, or sections in this Agreement shall not affect the validity of the remaining portions of this Agreement, so long as the material purpose of this Agreement can be determined and effectuated.

F. No Waiver. Any failure by either Party to enforce any of the provisions of this Agreement or to require compliance with any of its terms shall in no way affect the validity of this Agreement, or any part hereof, and shall not be deemed a waiver of the right of such Party thereafter to enforce any such provision.

G. Counterparts. This Agreement may be signed in any number of counterparts, and all such counterparts together shall constitute one and the same instrument. A signed copy of this Agreement delivered by facsimile, email, or other means of electronic transmission shall be deemed to have the same legal effect as delivery of an original signed copy of this Agreement.

H. Amendments and Waivers. This Agreement may be amended, modified, or supplemented only by an agreement in writing signed by each Party hereto. No waiver by either Party of any of the provisions hereof shall be effective unless explicitly set forth in writing and signed by the Party so waiving.

I. Notices. All notices, requests, consents, claims, demands, waivers, and other communications hereunder shall be in writing and shall be deemed to have been given (a) when delivered by hand (with written confirmation of receipt); or (b) on the third (3<sup>rd</sup>) day after the date mailed, by certified or registered mail, return receipt requested, postage prepaid. Such communications must be sent to the respective Parties at the addresses indicated below (or at such other address for a Party as shall be specified in a notice given in accordance with this **Section VI.I**):

If to the City:

City of High Point  
City Manager's Office  
211 South Hamilton Street  
P.O. Box 230  
High Point, NC 27261

If to the Organization:

(See Organization's address for notices on the signature page hereof.)

J. Disclosure. Organization agrees that it shall make no statements, press releases, or publicity releases concerning this Agreement or its subject matter or otherwise disclose or permit to be disclosed any of the data or other information obtained or furnished in compliance with this Agreement, or any particulars, thereof, without first notifying the City and securing its consent in writing.

K. Interpretation. For purposes of this Agreement, (a) the words "include," "includes," and "including" shall be deemed to be followed by the words "without limitation"; (b) the word "or" is not exclusive; and (c) the words "herein," "hereof," "hereby," "hereto," and "hereunder" refer to this Agreement as a whole. Unless the context otherwise requires, references herein: (x) to an agreement, instrument, or other document means such agreement, instrument, or other document as amended, supplemented, and modified from time to time to the extent permitted by the provisions thereof, and (y) to a statute means such statute as amended from time to time and includes any successor legislation thereto and any regulations promulgated thereunder. This Agreement shall be construed without regard to any presumption or rule requiring construction or interpretation against the party drafting an instrument or causing any instrument to be drafted. The Exhibits referred to herein shall be construed with, and as an integral part of, this Agreement to the same extent as if they were set forth verbatim herein.

L. Continuation of Performance During Dispute. During the pendency of any dispute between the Parties arising out of or relating to this Agreement, provided that Organization's continued performance is requested by the City in writing, it shall be the responsibility of Organization to continue to perform in conformity with the Agreement. For the avoidance of doubt, the provisions of this **Section VI.L** shall not apply in the event of a termination of this Agreement pursuant to **Section IV**.

M. Representation of Authority. Any individual executing this Agreement on behalf of Organization hereby represents and warrants that he or she is, on the date he or she signs this Agreement, duly authorized by all necessary and appropriate action to execute this Agreement on behalf of Organization and does so with full legal authority.

*[SIGNATURES BEGIN ON THE NEXT PAGE]*

**IN WITNESS WHEREOF**, this Agreement is entered into by the Parties as of the Effective Date.

**Organization:**

HIGH POINT INTERNATIONAL HOME  
FURNISHINGS MARKET AUTHORITY  
CORPORATION

By: \_\_\_\_\_

Name: \_\_\_\_\_

Title: \_\_\_\_\_

*Organization's address for notices:*

\_\_\_\_\_

\_\_\_\_\_

\_\_\_\_\_

Attn.: \_\_\_\_\_



**The City:**

CITY OF HIGH POINT

By: \_\_\_\_\_

Name: \_\_\_\_\_

Title: \_\_\_\_\_

**Preaudit Certificate**

This instrument has been preaudited in the manner required by the Local Government Budget and Fiscal Control Act.

\_\_\_\_\_  
Bobby Fitzjohn, Finance Officer

**EXHIBIT A**

**to**

**NON-PROFIT ORGANIZATION AGREEMENT**

Core City Showroom District

(See attached)

**EXHIBIT B**

**to**

**NON-PROFIT ORGANIZATION AGREEMENT**

South Main Street Project Underground Conversion

(See attached)

# CORE CITY SHOWROOM DISTRICT AND CB ZONING DISTRICT

## EXHIBIT A HIGH POINT, NC

 Central Business (CB)

 Showroom District from  
Core City Plan

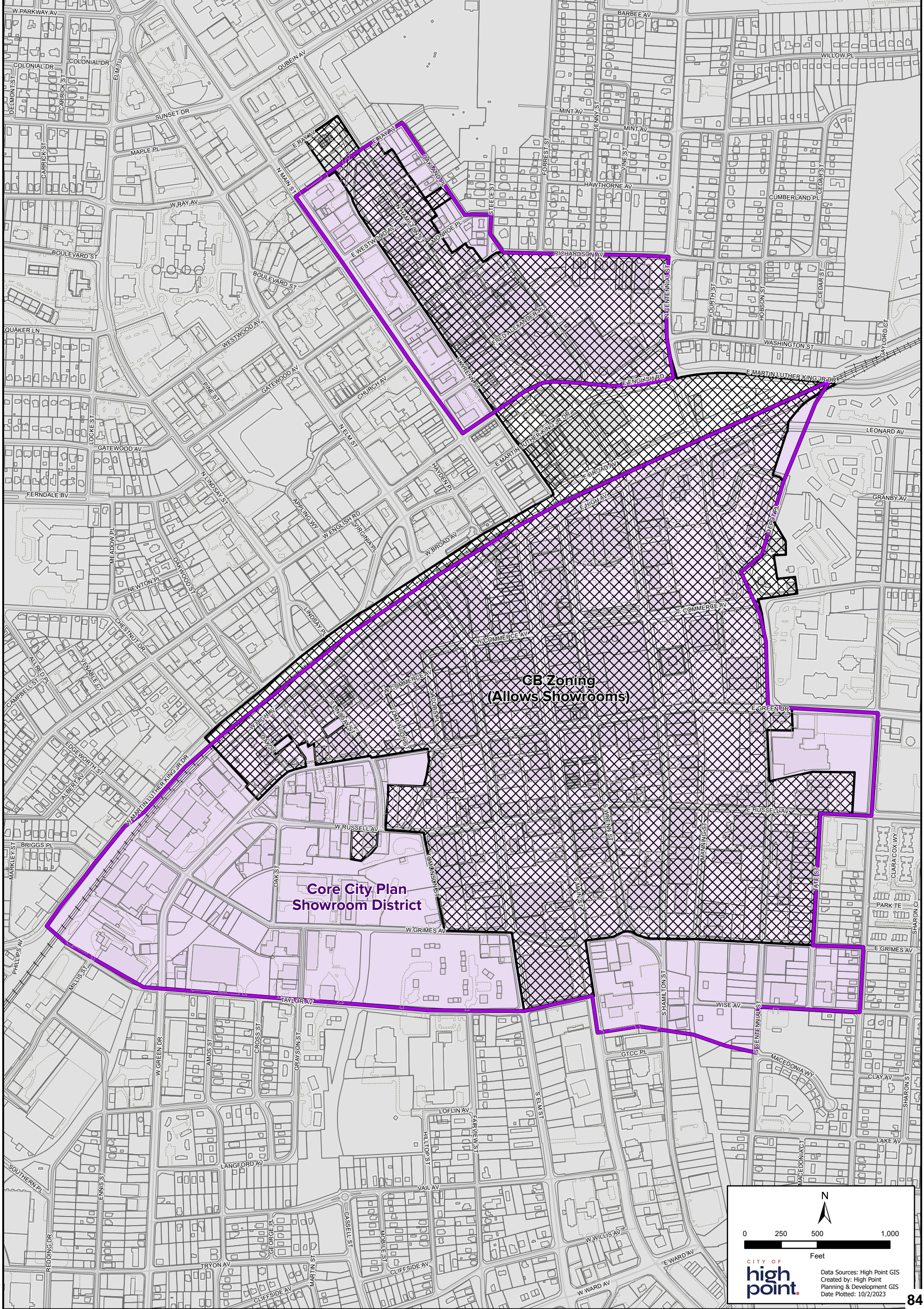

0 250 500 1,000  
Feet

**CITY OF**  
**high point.**

Data Sources: High Point GIS  
Created by: High Point  
Planning & Development GIS  
Date Plotted: 10/2/2023

84



CITY OF HIGH POINT  
 DEPARTMENT OF ELECTRIC UTILITIES  
 P.O. BOX 230, HIGH POINT NC 27265  
 (336) 883-3100  
 Date: 7/5/2023

## S MAIN PROJECT UNDERGROUND CONVERSION

# EXHIBIT B



# City of High Point

Municipal Office Building  
211 S. Hamilton Street  
High Point, NC 27260

## Master

**File Number: 2024-034**

**File ID:** 2024-034

**Type:** Resolution

**Status:** To Be Introduced

**Version:** 1

**Reference:**

**In Control:** Finance Committee

**File Created:** 01/25/2024

**File Name:**

**Final Action:**

**Title:** Consideration of a Contract with Community Housing Solutions  
City Council is requested to approve a contract with Community Housing Solutions in the amount \$419,184 to construct six affordable homes in the Cedrow Affordable Housing Project, adopt a resolution approving conveyance of real property to a nonprofit corporation, and authorize the appropriate City Official(s) to execute all necessary documents.

**Notes:**

**Sponsors:**

**Enactment Date:**

**Attachments:** Contract and Resolution - Community Housing Solutions

**Enactment Number:**

**Contact Name:**

**Hearing Date:**

**Drafter Name:** sandra.keeney@highpointnc.gov

**Effective Date:**

### History of Legislative File

Ver- sion:	Acting Body:	Date:	Action:	Sent To:	Due Date:	Return Date:	Result:

# CITY OF HIGH POINT

## AGENDA ITEM



<b>TITLE:</b> Community Housing Solutions CHDO Agreement and Property Conveyance	
<b>FROM:</b> Thanena Wilson, Director Community Development & Housing	<b>MEETING DATE:</b> February 5, 2024
<b>PUBLIC HEARING:</b> N/A	<b>ADVERTISED DATE/BY:</b> N/A
<b>ATTACHMENTS:</b> 1) Resolution of Conveyance of Real Property 2) Map and House Plans	

### PURPOSE:

The Community Development and Housing Department proposes to execute a contract with Community Housing Solutions (CHS) in the amount of \$419,184 to construct six affordable homes in the Cedrow Affordable Housing Project. Construction is expected to begin in February. Construction of these six units will complete the Cedrow Project.

Properties located at 1506, 1507 and 1511 Kingsway Drive, along with 1465, 1469 and 1473 Cedrow Drive are to be conveyed to CHS for construction and continued development of this affordable housing community. This contract will also include needed grading for 3 of the lots.

### BACKGROUND:

CHS has been a Community Housing Development Organization (CHDO) with the City of High Point since 2015. A CHDO is a private nonprofit, community-based service organization whose primary purpose is to provide and develop decent, safe, and affordable housing for the community it serves. CHS has met HUD requirements for designation as a CHDO based on their mission, housing development experience, and governing board composition, and has therefore been certified by the department. In addition to meeting CHDO requirements, CHS has demonstrated the organizational capacity and willingness to be a valued partner to the City of High Point as we work together to build much needed affordable housing in our community.

### BUDGET IMPACT:

The funding source for this contract is federal HOME funds. There are sufficient funds in the FY2023-24 budget.

### RECOMMENDATION / ACTION REQUESTED:

The Community Development and Housing Department recommends approval of the contract, conveyance of the properties, and that the appropriate City official and/or employee be authorized to execute all necessary documents.

**RESOLUTION of the HIGH POINT CITY COUNCIL  
APPROVING CONVEYANCE  
OF REAL PROPERTY  
TO A NONPROFIT CORPORATION**

**WHEREAS**, the City of High Point owns a tract of land recorded in Plat Book 202, Pages 148-149, recorded in the Guilford County Register of deeds, which contains the following properties: 1506, 1507 and 1511 Kingsway Drive, and 1465, 1469 and 1473 Cedrow Drive, High Point, NC (“Property”); and

**WHEREAS**, North Carolina General Statute § 160A-457 authorizes a city’s acquisition and disposition of property for redevelopment as part of a community development program, or independently thereof, and without the necessity of compliance with the Urban Redevelopment Law; and

**WHEREAS**, North Carolina General Statute § 160A-20.1 authorizes a city to appropriate money to private organizations to carry out any public purpose that a city is authorized by law to engage in; and

**WHEREAS**, North Carolina General Statute § 160A-279 authorizes a city to convey real property by private sale to a nonprofit corporation which carries out a public purpose, in lieu of or in addition to the appropriation of funds; and

**WHEREAS**, the City of High Point has executed a contract with Community Housing Solutions of Guilford, Inc. to construct affordable housing in the City of High Point by conveying the above-described Property to Community Housing Solutions of Guilford, Inc.

**THEREFORE, THE CITY COUNCIL FOR THE CITY OF HIGH POINT RESOLVES THAT:**

1. The Mayor of the City of High Point is authorized to execute all documents necessary to convey title to the Properties located at 1506, 1507 and 1511 Kingsway Drive, and 1465, 1469 and 1473 Cedrow Drive in the City of High Point, and more particularly described in Plat Book 202, Pages 148-149 of the Guilford County Registry.

2. The consideration of the conveyance is Community Housing Solutions of Guilford, Inc.’s agreement to use this property only for the “public” purpose of furthering the mission of the City of High Point in providing owner-occupied housing. If for any reason the property ceases to be used for a “public” purpose, the property shall revert to the City of High Point. A statement to this effect shall be placed in the deed of conveyance.

3. The City Clerk shall publish a notice summarizing the contents of this resolution and the conveyance of the property may be consummated at any time after 10 days of publication of the notice.

**ADOPTED** this the 5th day of February 2024.

CITY OF HIGH POINT

By: \_\_\_\_\_

Cyril Jefferson, Mayor

Attested to:

\_\_\_\_\_  
Sandra R. Keeney, City Clerk



CITY OF HIGH POINT  
AGENDA ITEM

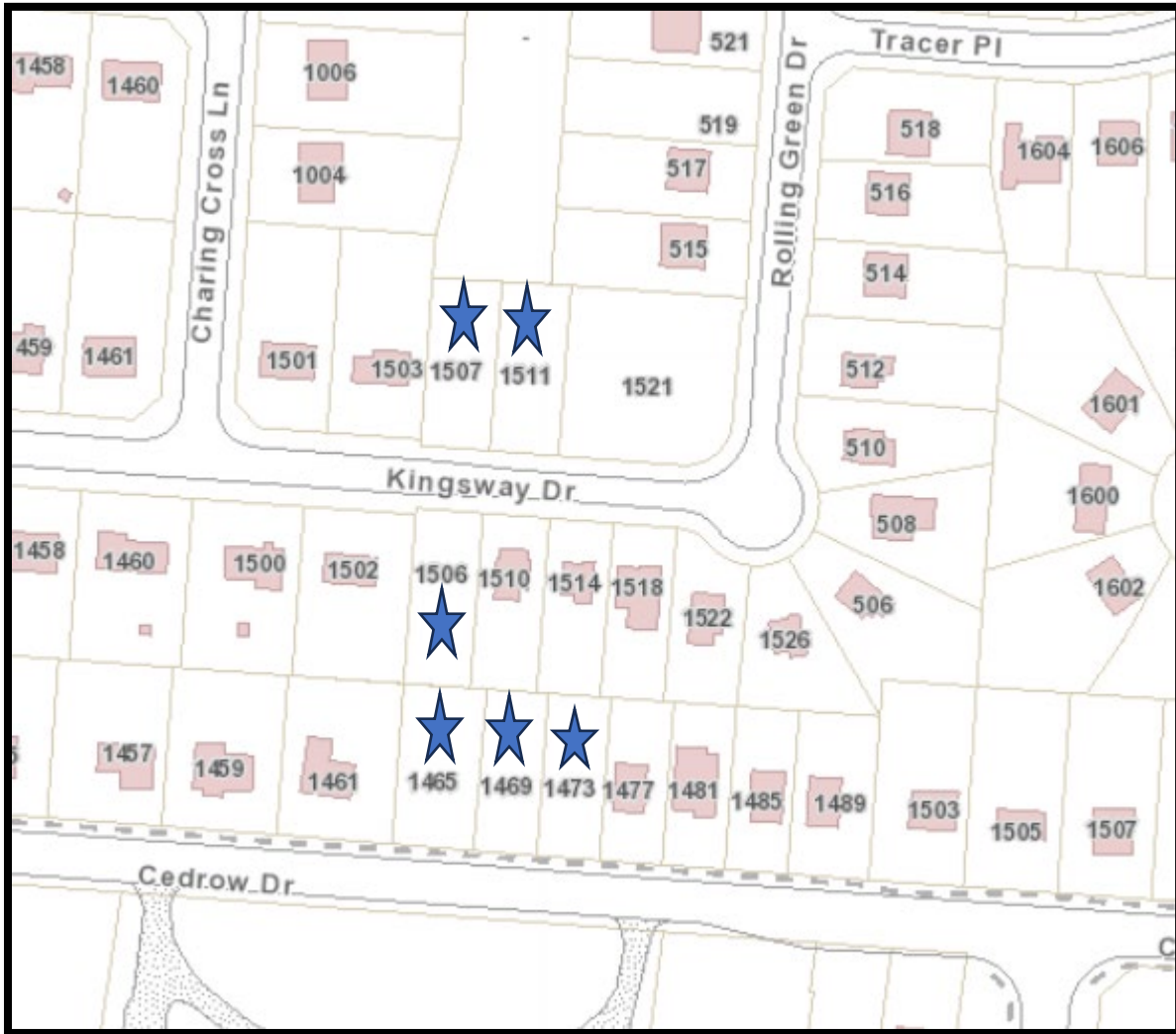

# TightLines Designs

creating great places to live



## Fisher III

This two story turn of the century style house of 1483 square feet features a large open living and dining area, spacious kitchen, and a private master bedroom suite.

The plan includes a total of three bedrooms, two full bathrooms, a powder room, a laundry room, and a U-shaped kitchen with a breakfast bar that opens to the dining room.

The Queen Anne inspired exterior offers a hip roof, a full front porch with a hip roof and gabled entry, covered rear porch, and exterior storage room. At 25'4" in width, it is ideally suited for a narrow lot.

Also available: Fisher I, Fisher II.  
Modifications available upon request.

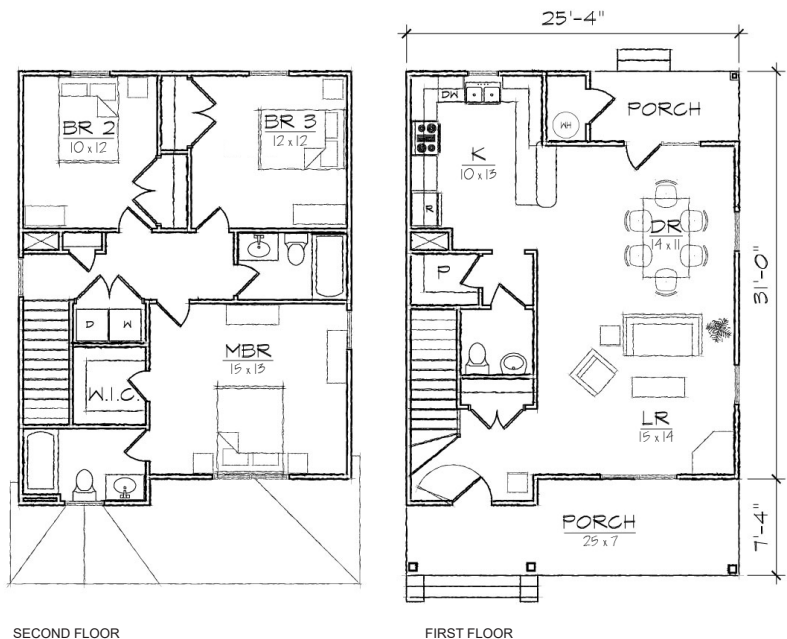

### Specifications

bedrooms: **3** square footage: **1483** roof pitch: **8/12**  
bathrooms: **2.5** 1st floor ceiling: **9'** width: **25' 4"**  
stories: **2** 2nd floor ceiling: **8'** depth: **38' 4"**

# TightLines Designs

creating great places to live



## Carlisle III

This single story bungalow style house of 1492 square feet features a dramatic large open vaulted living and dining room area and a private master bedroom suite located in the rear.

The plan includes a total of three bedrooms, two full bathrooms, a laundry area, and a centralized galley kitchen that opens to the dining and living areas.

The Arts and Crafts inspired exterior offers a double gabled roof, projecting front bay, covered front and rear porches, and exterior storage room.

Also available: Carlisle 2BR, Carlisle I, Carlisle II.  
 Modifications available upon request.

### Specifications

bedrooms: <b>3</b>	square footage: <b>1492</b>	roof pitch: <b>8/12</b>
bathrooms: <b>2</b>	1st floor ceiling: <b>9'</b>	width: <b>34'</b>
stories: <b>1</b>		depth: <b>55'</b>

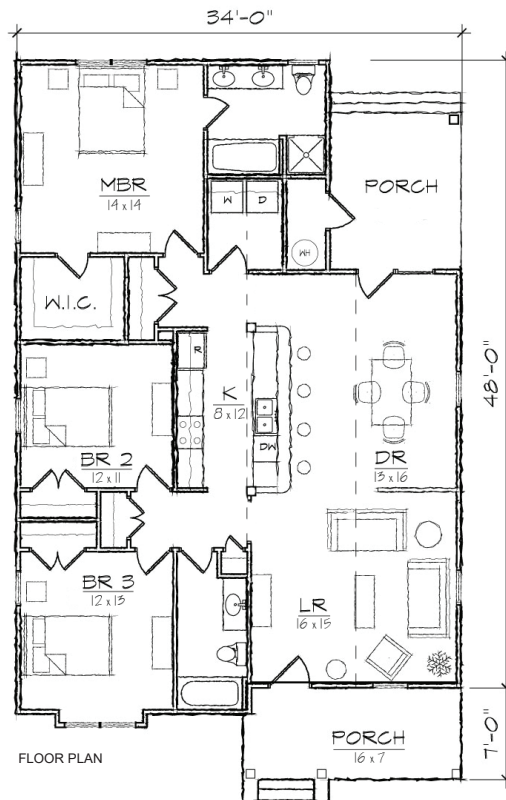

# TightLines Designs

creating great places to live



## Austin III

This one and one half story bungalow style home of 1489 square feet features a large open living and dining area and a first floor master bedroom suite. The plan includes a total of four bedrooms, two full bathrooms, a powder room, a laundry/mud room and an L-shaped kitchen with a breakfast bar that opens to the dining room. In addition to three bedrooms and a full bathroom, the second floor contains abundant, easily accessible storage.

The Arts and Crafts inspired exterior offers a front gabled roof and covered front and rear porches. At 26 ft in width, it is ideally suited for a narrow lot.

*Modifications available upon request.*

### Specifications

bedrooms: **4** square footage: **1489** roof pitch: **12/12**  
 bathrooms: **2.5** 1st floor ceiling: **9'** width: **26'**  
 stories: **2** 2nd floor ceiling: **8'** depth: **47'**

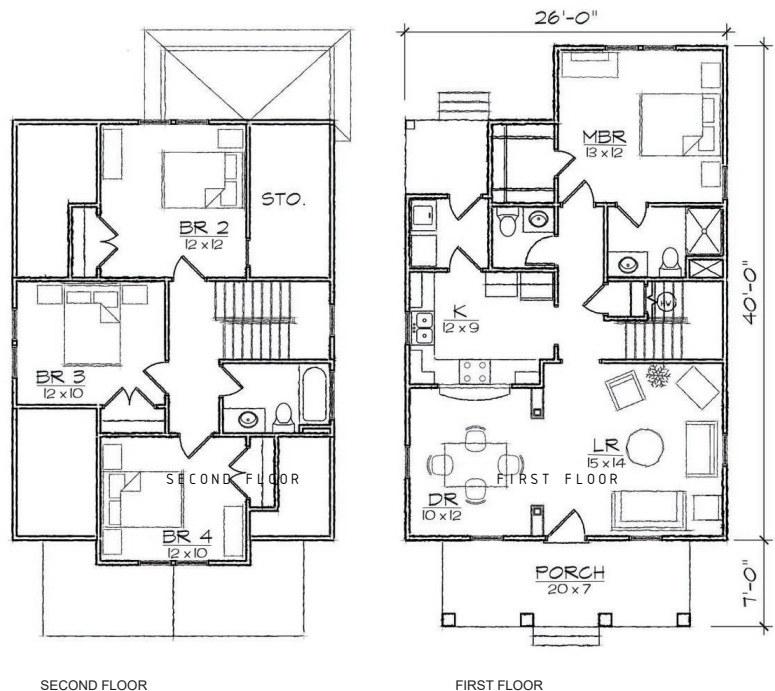



# City of High Point

Municipal Office Building  
211 S. Hamilton Street  
High Point, NC 27260

## Master

**File Number: 2024-035**

**File ID:** 2024-035

**Type:** Miscellaneous Item

**Status:** To Be Introduced

**Version:** 1

**Reference:**

**In Control:** Finance Committee

**File Created:** 01/25/2024

**File Name:**

**Final Action:**

**Title:** Consideration of Acceptance of a Grant Award from the U.S. Small Business Administration  
City Council is requested to accept a grant award from the U.S. Small Business Administration in the amount of \$2,000,000 for development of a commercial shared-use kitchen, approve a budget ordinance amendment, and authorize the appropriate City Official(s) to execute all necessary documents.

**Notes:**

**Sponsors:**

**Enactment Date:**

**Attachments:** SBA Grant - Commercial Shared Use Kitchen

**Enactment Number:**

**Contact Name:**

**Hearing Date:**

**Drafter Name:** sandra.keeney@highpointnc.gov

**Effective Date:**

### History of Legislative File

Ver- sion:	Acting Body:	Date:	Action:	Sent To:	Due Date:	Return Date:	Result:

# CITY OF HIGH POINT

## AGENDA ITEM



<b>TITLE:</b> Budget Amendment: Commercial Shared-Use Kitchen Community Project Award, U.S. Small Business Administration	
<b>FROM:</b> Thanena Wilson, Director Community Development & Housing	<b>MEETING DATE:</b> February 5, 2024
<b>PUBLIC HEARING:</b> N/A	<b>ADVERTISED DATE/BY:</b> N/A
<b>ATTACHMENTS:</b> 1) Budget Ordinance Amendment 2) Grant #SBAHQ23I0149 Notice of Award	

### **PURPOSE:**

Staff is requesting approval of a budget ordinance amendment for funding received in the amount of \$2,000,000 through the U.S. Small Business Administration as a result of support through Representative Kathy Manning and the Community Project Funding opportunity. The requested funds would be used for the development of a commercial shared-use kitchen in the southwest area of High Point. The funds would specifically be used for building costs and equipment.

### **BACKGROUND:**

Southwest High Point has faced historical underinvestment. It is in census tract 143, which meets the definition of an Area of Persistent Poverty as defined by the 2021 Consolidated Appropriations Act. This project would represent a significant investment in this community, which is largely low-income and African American. This is an opportunity to help revitalize this area by offering new job opportunities within walking distance of an underserved neighborhood, as well as providing a needed service to the food industry at large.

### **BUDGET IMPACT:**

A budget ordinance amendment appropriating the federal grant award is included with this item.

### **RECOMMENDATION /ACTION REQUESTED:**

The Community Development and Housing Department recommends approval accepting the grant award, approve the budget ordinance for the Commercial Shared-Use Kitchen, and that the appropriate City official and/or employee be authorized to execute all necessary documents.

“AN ORDINANCE AMENDING THE 2023-2024 BUDGET ORDINANCE  
OF THE CITY OF HIGH POINT, NORTH CAROLINA  
TO APPROPRIATE FUNDS FOR THE COMMERCIAL SHARED-USE KITCHEN GRANT

Be it ordained by the City Council of the City of High Point, North Carolina, as follows:

Section 1. The proposed amendment appropriates \$2,000,000 in federal grant funds to assist in the construction and development of a Commercial Shared-Use Kitchen in High Point.

Section 2. The 2023-2024 Budget Ordinance of the City of High Point should be amended as follows:

(A) That the following Special Revenue Fund revenues be amended as follows:

Federal Grants – U.S. Department of Commerce	\$2,000,000
--	-------------

(B) That the following Special Revenue Fund expenditures be amended as follows:

Commercial Shared-Used Kitchen	\$2,000,000
--------------------------------	-------------

Section 3. That all ordinances, or parts of ordinances in conflict with this ordinance are hereby repealed to the extent of such conflict.

Section 4. That this ordinance shall be effective from and after its passage."

Adopted by High Point City Council, this the 5th day of February 2024

\_\_\_\_\_  
Cyril Jefferson, Mayor

ATTEST

\_\_\_\_\_  
Sandra Keeney, City Clerk

U.S. Small Business Administration

# NOTICE OF AWARD

**1. AUTHORIZATION** (Legislation/Regulation)  
H.R. 2617 the Consolidated Appropriations Act of 2023

**2. Grant/Cooperative Agreement No.:**

SBAHQ23I0149

**3. RECIPIENT:** (Name, Organizational Unit, Address)

City of High Point  
211 South Hamilton Street Suite 307  
High Point, North Carolina 27260-5232

**4. PROJECT PERIOD** (Mo./Day/Yr.) (Mo./Day/Yr.)  
From 1/1/2024 Through 12/31/2026

**5. BUDGET PERIOD** (Mo./Day/Yr.) (Mo./Day/Yr.)  
From 1/1/2024 Through 12/31/2026

**8. TITLE OF PROJECT/PROGRAM** (limit to 53 spaces)  
Congressional Earmarks Initiative

**6. FEDERAL CATALOG NO.** 59.059  
**7. ADMINISTRATIVE CODES** 303020

**9. AWARD AMOUNT**  
Amount of SBA Financial Assistance \$2,000,000

**10. DIRECTOR OF PROJECT** (Program or Center Director, Coordinator or Principal Investigator)

**NAME** Olmedo, Eric  
Last First Initial  
**ADDRESS:** 211 South Hamilton Street Suite 307  
Starkville, Mississippi 39759-7754

**11. RECOMMENDED FUTURE SUPPORT** (Subject to the availability of funds and satisfactory progress of the project)

BUDGET YEAR	TOTAL DIRECT COST	BUDGET YEAR	TOTAL DIRECT COST
a.		b.	

**12. Approved Budget** (Excludes SBA Direct Assistance)

**13. REMARKS** (Other Terms & Conditions Attached)  Yes  No

SBA Funds Only  Total project costs including all other financial participation.

	Federal Share	Non-Federal Share	Non-Federal In-Kind	Non-Federal Program Inc.
a. Personal Service.....				
b. Fringe Benefits.....				
c. Consultants.....				
d. Travel.....				
e. Equipment.....				
f. Supplies.....				
g. Contractual.....				
h. Other Construction.....	2000000			
<b>i. TOTAL DIRECT COSTS.....</b>	<b>2,000,000</b>			
<b>j. Indirect cost.....</b> (Rate).				
<b>k. OTHER APPL. COSTS.....</b>				
<b>l. TOTAL APPROVED BUDGET</b>	<b>2,000,000</b>			

**14. THIS AWARD IS SUBJECT TO THE FOLLOWING COST PRINCIPLES AND OMB UNIFORM ADMINISTRATIVE REQUIREMENTS:**

- 2 CFR Chapter 1, Chapter II, Part 200, et al, uniform Administrative Requirements, Cost Principles, and Audit Requirements for Federal Awards.
- Part 180 - OMB Guidelines to Agencies on government debarment and suspension (Non Procurement)

**\*Must meet all matching or cost participation requirements subject to adjustment in accordance with SBA policy**

**15. THIS AWARD IS SUBJECT TO THE TERMS AND CONDITIONS ON THE REVERSE SIDE**

16. CRS - EIN 56-6000231		17. COUNTY NAME Guilford		18. CONGRESSIONAL DISTRICT NO. NC-006	
19a. CITY CODE 31400	b. COUNTY CODE 057	c. STATE CODE 37	d. PROGRAM CODE		
<b>BUDGET CODE</b>		<b>DOCUMENT NO.</b>		<b>AMT. ACTION FIN. ASST.</b>	
20a. 735100	b.	c. \$2,000,000	d. C		
21. AGENCY OFFICIAL (Signature, Name and Title)			22. DATE ISSUED (Mo./Day/Yr.)		
23. RECIPIENT OFFICIAL (Signature, Name and Title)			24. DATE (Mo./Day/Yr.)		



Note: The estimated burden completing this form is 80 hours per response. You will not be required to respond to any collection of information unless it displays a currently valid OMB approval number. Comments on the burden should be sent to U.S. Small Business Administration, Chief, AIB, 409, 3rd St., S.W., Washington, D.C. 20416 and Desk Office for Small Business Administration, Office of Management and Budget, New Executive Office Building, room 10202 Washington, D.C. 20503. OMB Approval (3245-0140).  
PLEASE DO NOT SEND FORMS TO OMB.



# City of High Point

Municipal Office Building  
211 S. Hamilton Street  
High Point, NC 27260

## Master

**File Number: 2024-036**

**File ID:** 2024-036

**Type:** Miscellaneous Item

**Status:** To Be Introduced

**Version:** 1

**Reference:**

**In Control:** Finance Committee

**File Created:** 01/25/2024

**File Name:**

**Final Action:**

**Title:** Consideration of a Contract with Excel Truck Group  
City Council is requested to award a contract to Excel Truck Group in the amount of \$156,642.00 for the purchase of 2024 Freightliner M2 106 Plus and authorize the appropriate City Official(s) to execute all necessary documents.

**Notes:**

**Sponsors:**

**Enactment Date:**

**Attachments:** Contract - Excel Truck Group

**Enactment Number:**

**Contact Name:**

**Hearing Date:**

**Drafter Name:** sandra.keeney@highpointnc.gov

**Effective Date:**

### History of Legislative File

Ver- sion:	Acting Body:	Date:	Action:	Sent To:	Due Date:	Return Date:	Result:

# CITY OF HIGH POINT

## AGENDA ITEM



<b>TITLE:</b> Contract Purchase for Freightliner M2-106 Plus	
<b>FROM:</b> Thomas Reid, Fire Chief	<b>MEETING DATE:</b> February 5, 2024
<b>PUBLIC HEARING:</b> n/a	<b>ADVERTISED DATE/BY:</b> n/a
<b>ATTACHMENTS:</b> Excel Truck Group -NCSA Contract #24-08-0421	

### **PURPOSE:**

High Point Fire Department request replacement of a 2006 Freightliner M2-106 Road Chassis.

### **BACKGROUND:**

In accordance with National Fire Protection Association (NFPA) 1901, Standard Automotive Fire Apparatus, the City of High Point adopted a 15-year Fleet Replacement Plan for fire apparatus.

High Point Fire Department has a 2006 M2 106 Plus Freightliner serving as the road tractor for the Hazardous Materials Response Team that needs replacement due to age, hours, and maintenance ability to locate parts for the command center.

Upon delivery of the new Freightliner M2 106 Plus, the 2006 Freightliner will be transferred to reserve status.

The 2024 Freightliner M2 106 Plus has a purchase price of \$156,642.00.

### **BUDGET IMPACT:**

Funding is available in the 2023-2024 budget appropriated by City Council.

### **RECOMMENDATION/ACTION REQUESTED:**

Using the NC Sherriff's Association (NCSA) procurement contract, the High Point Fire Department request Council's approval for purchase of a 2024 Freightliner M2 106 Plus from Excel Truck Group in the amount of \$156,642.00 and that the appropriate City official and/or employee be authorized to execute all necessary documents. Once receipt of purchase order, the expected delivery could range from 18 to 24 months.



**CITY OF HIGH POINT**  
**AGENDA ITEM**



**BID RECOMMENDATION**

DEPARTMENT:

COUNCIL AGENDA DATE:

BID NO.:  CONTRACT NO.:  DATE OPEN:

DESCRIPTION:

PURPOSE:

COMMENTS:

RECOMMEND AWARD TO:  AMOUNT:

JUSTIFICATION:

ACCOUNTING UNIT	ACCOUNT	ACTIVITY	CATEGORY	BUDGETED AMOUNT
401350	533101			156,642.00
TOTAL BUDGETED AMOUNT				

DEPARTMENT HEAD:  Digitally signed by Thomas Reid  
DN: cn=Thomas Reid, o=City of High Point, ou=High Point Fire Department, email=thomas.reid@highpointnc.gov, c=US  
Date: 2024.01.25 13:38:01 -0500 DATE:

The Purchasing Division concurs with recommendation submitted by the  and recommends award to the lowest responsible, responsive bidder  in the amount of

PURCHASING MANAGER:  Digitally signed by Candy E. Harmon  
Date: 2024.01.25 13:47:43 -0500 DATE:

Approved for Submission to Council

FINANCIAL SERVICES DIRECTOR:  Digitally signed by Bobby Fitzjohn  
Date: 2024.01.25 14:12:15 -0500 DATE:

CITY MANAGER:  DATE:

(For City Council Approval Only)

**Prepared for:**  
Jason Bennett  
NC SHERIFFS ASSOCIATION  
PO BOX 20049  
RALEIGH, NC 27619  
Phone: 919.459.6471



**NCSA Contract#24-08-0421**  
**Freightliner M2-106**

**Prepared by:**  
Tony Lyerly  
EXCEL TRUCK GROUP.  
4633 EQUIPMENT DRIVE  
CHARLOTTE, NC 28269  
Phone: 704-597-1110

*A proposal for*  
**NC SHERIFFS ASSOCIATION**  
**City of High Point**

*Prepared by*  
**EXCEL TRUCK GROUP**  
*Tony Lyerly*

*Jan 01, 2024*

**Freightliner M2 106 Plus**

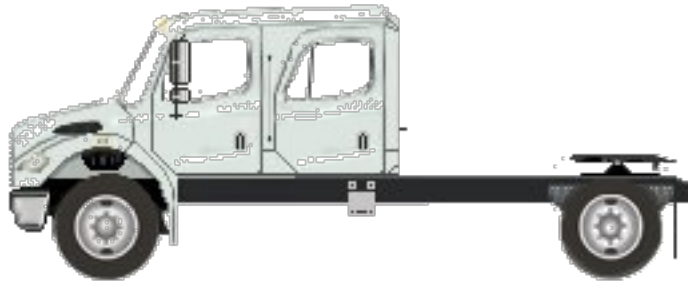

Application Version 11.9.412  
Data Version PRL-28M.024  
City of High Point EMS



01/01/2024 1:19 PM

Page 1 of 21

Prepared for:  
 Jason Bennett  
 NC SHERIFFS ASSOCIATION  
 PO BOX 20049  
 RALEIGH, NC 27619  
 Phone: 919.459.6471



**NCSA Contract#24-08-0421**  
**Freightliner M2-106**

Prepared by:  
 Tony Lyerly  
 EXCEL TRUCK GROUP.  
 4633 EQUIPMENT DRIVE  
 CHARLOTTE, NC 28269  
 Phone: 704-597-1110

**QUOTATION**

**M2 106 PLUS CONVENTIONAL CHASSIS**

SET BACK AXLE - TRACTOR  
 CUM L9 330EV HP @ 2200 RPM, 2200 GOV RPM, 1000  
 LB-FT @ 1200 RPM, R/F/E  
 ALLISON 3000 EVS AUTOMATIC TRANSMISSION WITH  
 PTO PROVISION  
 RS-23-160 23,000# R-SERIES SINGLE REAR AXLE  
 23,000# FLAT LEAF SPRING REAR SUSPENSION WITH  
 HELPER AND RADIUS ROD  
 DETROIT DA-F-12.0-3 12,000# FF1 71.5 KPI/3.74 DROP  
 SINGLE FRONT AXLE

12,000# DUAL TAPERLEAF FRONT SUSPENSION  
 154 INCH BBC HIGH-ROOF ALUMINUM CONVENTIONAL  
 CREW CAB  
 4825MM (190 INCH) WHEELBASE  
 FONTAINE 7000 SERIES 7PML FLAT PLATE MOUNT  
 STATIONARY FIFTH WHEEL  
 11/32X3-1/2X10-3/16 INCH STEEL FRAME  
 (8.73MMX258.8MM/0.344X10.19 INCH) 120KSI  
 950MM (37 INCH) REAR FRAME OVERHANG

			PER UNIT		TOTAL
VEHICLE PRICE	TOTAL # OF UNITS (1)	\$	111,487	\$	111,487
EXTENDED WARRANTY		\$	115	\$	115
DEALER INSTALLED OPTIONS		\$	0	\$	0
<b>CUSTOMER PRICE BEFORE TAX</b>		\$	<b>111,602</b>	\$	<b>111,602</b>

**TAXES AND FEES**

FEDERAL EXCISE TAX (FET)	\$	(151)	\$	(151)
SHERIFF FEES	\$	837	\$	837
OTHER CHARGES	\$	0	\$	0

**TRADE-IN**

TRADE-IN ALLOWANCE	\$	(0)	\$	(0)
--------------------	----	-----	----	-----

<b>BALANCE DUE</b>	<b>(LOCAL CURRENCY)</b>	\$	<b>112,288</b>	\$	<b>112,288</b>
--------------------	-------------------------	----	----------------	----	----------------

COMMENTS:

Projected delivery on \_\_\_ / \_\_\_ / \_\_\_ provided the order is received before \_\_\_ / \_\_\_ / \_\_\_.

APPROVAL:

Please indicate your acceptance of this quotation by signing below:

Customer: X \_\_\_\_\_ Date: \_\_\_ / \_\_\_ / \_\_\_.

**Daimler Truck Financial**

Financing that works for you.

See your local dealer for a competitive quote from Daimler Truck Financial, or contact us at [Information@dtfoffers.com](mailto:Information@dtfoffers.com).

Daimler Truck Financial offers a variety of finance, lease and insurance solutions to fit your business needs. For more information about our products and services, visit our website at [www.daimler-truckfinancial.com](http://www.daimler-truckfinancial.com).

Application Version 11.9.412  
 Data Version PRL-28M.024  
 City of High Point EMS



01/01/2024 1:19 PM

Page 2 of 21

**Prepared for:**  
Jason Bennett  
NC SHERIFFS ASSOCIATION  
PO BOX 20049  
RALEIGH, NC 27619  
Phone: 919.459.6471



**NCSA Contract#24-08-0421**  
**Freightliner M2-106**

**Prepared by:**  
Tony Lyerly  
EXCEL TRUCK GROUP.  
4633 EQUIPMENT DRIVE  
CHARLOTTE, NC 28269  
Phone: 704-597-1110





Prepared for:  
 Jason Bennett  
 NC SHERIFFS ASSOCIATION  
 PO BOX 20049  
 RALEIGH, NC 27619  
 Phone: 919.459.6471



**NCSA Contract#24-08-0421**  
**Freightliner M2-106**

Prepared by:  
 Tony Lyerly  
 EXCEL TRUCK GROUP.  
 4633 EQUIPMENT DRIVE  
 CHARLOTTE, NC 28269  
 Phone: 704-597-1110

**D I M E N S I O N S**

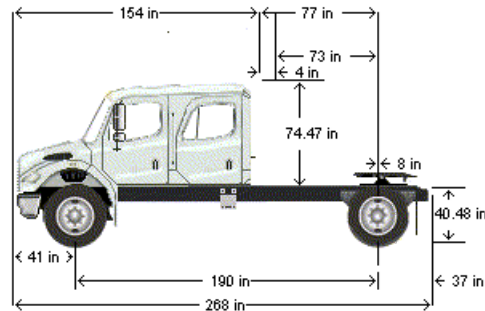

**VEHICLE SPECIFICATIONS SUMMARY - DIMENSIONS**

Model .....	M2106
Wheelbase (545).....	4825MM (190 INCH) WHEELBASE
Rear Frame Overhang (552).....	950MM (37 INCH) REAR FRAME OVERHANG
Fifth Wheel (578) .....	FONTAINE 7000 SERIES 7PML FLAT PLATE MOUNT STATIONARY FIFTH WHEEL
Mounting Location (577) .....	FIFTH WHEEL 203MM (08.0 INCHES) AHEAD OF SUSPENSION CENTERLINE
Maximum Forward Position (in) .....	8
Maximum Rearward Position (in).....	8
Amount of Slide Travel (in) .....	0
Slide Increment (in).....	0
Desired Slide Position (in).....	8.0
Cab Size (829).....	154 INCH BBC HIGH-ROOF ALUMINUM CONVENTIONAL CREW CAB
Sleeper (682) .....	NO SLEEPER BOX/SLEEPERCAB
Exhaust System (016).....	RH INBOARD FRAME MOUNTED HORIZONTAL AFTERTREATMENT SYSTEM ASSEMBLY WITH HORIZONTAL TAILPIPE

**TABLE SUMMARY - DIMENSIONS**



Prepared for:  
 Jason Bennett  
 NC SHERIFFS ASSOCIATION  
 PO BOX 20049  
 RALEIGH, NC 27619  
 Phone: 919.459.6471



**NCSA Contract#24-08-0421**  
**Freightliner M2-106**

Prepared by:  
 Tony Lyerly  
 EXCEL TRUCK GROUP.  
 4633 EQUIPMENT DRIVE  
 CHARLOTTE, NC 28269  
 Phone: 704-597-1110

Dimensions	Inches
Bumper to Back of Cab (BBC)	153.5
Bumper to Centerline of Front Axle (BA)	40.7
Front Axle to Back of Cab (AC)	112.8
Back of Cab to Centerline of Rear Axle(s) (CA)	77.2
Effective Back of Cab to Centerline of Rear Axle(s) (Effective CA)	73.0
Back of Cab Protrusions (Exhaust/Intake) (CP)	2.0
Back of Cab Protrusions (Side Extenders/Trim Tab) (CP)	0.0
Back of Cab Protrusions (CNG Tank)	0.0
Back of Cab Clearance (CL)	4.2
Back of Cab to End of Frame	114.6
Cab Height (CH)	74.5
Fifth Wheel to Centerline of Rear Axle(s) (FW)	8.0
Wheelbase (WB)	190.0
Frame Overhang (OH)	37.4
Overall Frame Length	266.3
Overall Length (OAL)	268.1
Rear Axle Spacing	0.0
Unladen Frame Height at Centerline of Rear Axle	40.5

Performance calculations are estimates only. If performance calculations are critical, please contact Customer Application Engineering.



Prepared for:  
 Jason Bennett  
 NC SHERIFFS ASSOCIATION  
 PO BOX 20049  
 RALEIGH, NC 27619  
 Phone: 919.459.6471



**NCSA Contract#24-08-0421**  
**Freightliner M2-106**

Prepared by:  
 Tony Lyerly  
 EXCEL TRUCK GROUP  
 4633 EQUIPMENT DRIVE  
 CHARLOTTE, NC 28269  
 Phone: 704-597-1110

## S P E C I F I C A T I O N P R O P O S A L

Data Code	Description	Weight Front	Weight Rear	Retail Price
<b>Price Level</b>				
PRL-28M	M2 PRL-28M (EFF:MY25 ORDERS)			STD
<b>Data Version</b>				
DRL-024	SPECPRO21 DATA RELEASE VER 024			N/C
<b>Vehicle Configuration</b>				
001-172	M2 106 PLUS CONVENTIONAL CHASSIS	5,709	3,450	\$114,401.00
004-225	2025 MODEL YEAR SPECIFIED			STD
002-002	SET BACK AXLE - TRACTOR	20		\$3,606.00
019-005	TRAILER TOWING PROVISION FORWARD OF FIFTH WHEEL	5	5	N/C
003-001	LH PRIMARY STEERING LOCATION			STD
<b>General Service</b>				
AA1-001	TRACTOR/TRAILER CONFIGURATION			N/C
AA6-002	DOMICILED, USA (EXCLUDING CALIFORNIA AND CARB OPT-IN STATES)			N/C
99D-021	EPA EMISSIONS CERTIFICATION FOR 50 STATE REGISTRATION - CARB EXEMPT, FIRE AND EMERGENCY VEHICLES ONLY (INCLUDES 6X4 INCH LABEL SHIPPED LOOSE)			N/C
AF2-998	NO STATE/PROVINCE INITIAL REGISTRATION SELECTED			N/C
A85-006	RESCUE AND EMERGENCY SERVICE			N/C
A84-1GM	GOVERNMENT BUSINESS SEGMENT			N/C
AA4-011	FIXED LOAD COMMODITY			N/C
AA5-002	TERRAIN/DUTY: 100% (ALL) OF THE TIME, IN TRANSIT, IS SPENT ON PAVED ROADS			STD
AB1-008	MAXIMUM 8% EXPECTED GRADE			STD
AB5-001	SMOOTH CONCRETE OR ASPHALT PAVEMENT - MOST SEVERE IN-TRANSIT (BETWEEN SITES) ROAD SURFACE			STD
995-091	MEDIUM TRUCK WARRANTY			STD
A66-99D	EXPECTED FRONT AXLE(S) LOAD : 12000.0 lbs			

Application Version 11.9.412  
 Data Version PRL-28M.024  
 City of High Point EMS



01/01/2024 1:19 PM

Page 6 of 21

Prepared for:  
 Jason Bennett  
 NC SHERIFFS ASSOCIATION  
 PO BOX 20049  
 RALEIGH, NC 27619  
 Phone: 919.459.6471



**NCSA Contract#24-08-0421**  
**Freightliner M2-106**

Prepared by:  
 Tony Lyerly  
 EXCEL TRUCK GROUP  
 4633 EQUIPMENT DRIVE  
 CHARLOTTE, NC 28269  
 Phone: 704-597-1110

Data Code	Description	Weight Front	Weight Rear	Retail Price
A68-99D	EXPECTED REAR DRIVE AXLE(S) LOAD : 23000.0 lbs			
A63-99D	EXPECTED GROSS VEHICLE WEIGHT CAPACITY : 35000.0 lbs			
A70-99D	EXPECTED GROSS COMBINATION WEIGHT : 80000.0 lbs			
<b>Truck Service</b>				
AF3-2CR	TRACTOR ONLY WITH NO BODY UPFIT			N/C
<b>Tractor Service</b>				
AA2-005	FLATBED TRAILER			N/C
AH6-001	SINGLE (1) TRAILER			N/C
<b>Engine</b>				
101-3BY	CUM L9 330EV HP @ 2200 RPM, 2200 GOV RPM, 1000 LB-FT @ 1200 RPM, R/F/E	640	30	\$13,196.00
<b>Electronic Parameters</b>				
79A-075	75 MPH ROAD SPEED LIMIT			N/C
79B-018	CRUISE CONTROL SPEED LIMIT 5 MPH HIGHER THAN ROAD SPEED LIMIT			N/C
79F-004	CUMMINS TRIP INFORMATION REPORTS ENABLED; LEVEL 1: 4 MPH, LEVEL 2: 7 MPH ABOVE ROAD SPEED LIMIT			N/C
79K-002	PTO MODE ENGINE RPM LIMIT - 700 RPM			N/C
79M-001	PTO MODE BRAKE OVERRIDE - SERVICE BRAKE APPLIED			N/C
79P-002	PTO RPM WITH CRUISE SET SWITCH - 700 RPM			N/C
79Q-002	PTO RPM WITH CRUISE RESUME SWITCH - 700 RPM			N/C
79S-001	PTO MODE CANCEL VEHICLE SPEED - 5 MPH			N/C
79V-001	FUEL DOSING OF AFTERTREATMENT ENABLED IN PTO MODE-CLEANS HYDROCARBONS AT HIGH TEMPERATURES ONLY			N/C
79W-001	ONE REMOTE PTO SPEED			N/C
79X-001	PTO SPEED 1 SETTING - 700 RPM			N/C
80G-002	PTO MINIMUM RPM - 700			N/C
80J-002	REGEN INHIBIT SPEED THRESHOLD - 5 MPH			N/C
N 80S-001	PTO 1, DASH SWITCH, STATIONARY OPERATION			N/C
<b>Engine Equipment</b>				
99C-024	EPA 2010/GHG 2024 CONFIGURATION			STD
13E-001	STANDARD OIL PAN			STD
105-001	ENGINE MOUNTED OIL CHECK AND FILL			STD

Application Version 11.9.412  
 Data Version PRL-28M.024  
 City of High Point EMS



01/01/2024 1:19 PM

Prepared for:  
 Jason Bennett  
 NC SHERIFFS ASSOCIATION  
 PO BOX 20049  
 RALEIGH, NC 27619  
 Phone: 919.459.6471



**NCSA Contract#24-08-0421**  
**Freightliner M2-106**

Prepared by:  
 Tony Lyerly  
 EXCEL TRUCK GROUP.  
 4633 EQUIPMENT DRIVE  
 CHARLOTTE, NC 28269  
 Phone: 704-597-1110

Data Code	Description	Weight Front	Weight Rear	Retail Price
014-1BX	SIDE OF HOOD AIR INTAKE WITH NFPA COMPLIANT EMBER SCREEN AND FIRE RETARDANT DONALDSON AIR CLEANER			\$102.00
124-114	LN 12V 280 AMP BLP4009 BRUSHLESS PAD ALTERNATOR WITH REMOTE SENSE AND LAMP TERMINAL	10		\$637.00
292-206	(3) DTNA GENUINE, FLOODED STARTING, MIN 2850CCA, 525RC, THREADED STUD BATTERIES	40	20	\$263.00
290-017	BATTERY BOX FRAME MOUNTED			STD
281-001	STANDARD BATTERY JUMPERS			STD
282-003	SINGLE BATTERY BOX FRAME MOUNTED LH SIDE BACK OF CAB			N/C
291-017	WIRE GROUND RETURN FOR BATTERY CABLES WITH ADDITIONAL FRAME GROUND RETURN			STD
289-001	NON-POLISHED BATTERY BOX COVER			STD
306-015	PROGRESSIVE LOW VOLTAGE DISCONNECT AT 12.3 VOLTS FOR DESIGNATED CIRCUITS			STD
107-032	CUMMINS TURBOCHARGED 18.7 CFM AIR COMPRESSOR WITH INTERNAL SAFETY VALVE			STD
108-002	STANDARD MECHANICAL AIR COMPRESSOR GOVERNOR			STD
131-013	AIR COMPRESSOR DISCHARGE LINE			STD
152-039	GVG, FIRE AND EMERGENCY SERVICE VEHICLES ENGINE WARNING			N/C
128-032	C-BRAKE BY JACOBS WITH LOW/OFF/HIGH BRAKING DASH SWITCH	80		\$2,553.00
N 016-101	RH INBOARD FRAME MOUNTED HORIZONTAL AFTERTREATMENT SYSTEM ASSEMBLY WITH HORIZONTAL TAILPIPE	-50	-50	(\$1,000.00)
28F-014	ENGINE AFTERTREATMENT DEVICE, AUTOMATIC OVER THE ROAD REGENERATION AND VIRTUAL REGENERATION REQUEST SWITCH IN CLUSTER			STD
239-001	STANDARD EXHAUST SYSTEM LENGTH			STD
237-052	RH STANDARD HORIZONTAL TAILPIPE			STD
23U-001	6 GALLON DIESEL EXHAUST FLUID TANK			STD
30N-003	100 PERCENT DIESEL EXHAUST FLUID FILL			STD
43X-002	LH MEDIUM DUTY STANDARD DIESEL EXHAUST FLUID TANK LOCATION			STD
23Y-001	STANDARD DIESEL EXHAUST FLUID PUMP MOUNTING			STD
43Y-001	STANDARD DIESEL EXHAUST FLUID TANK CAP			STD
273-058	AIR POWERED ON/OFF ENGINE FAN CLUTCH			STD



Prepared for:  
 Jason Bennett  
 NC SHERIFFS ASSOCIATION  
 PO BOX 20049  
 RALEIGH, NC 27619  
 Phone: 919.459.6471



**NCSA Contract#24-08-0421  
 Freightliner M2-106**

Prepared by:  
 Tony Lyerly  
 EXCEL TRUCK GROUP.  
 4633 EQUIPMENT DRIVE  
 CHARLOTTE, NC 28269  
 Phone: 704-597-1110

Data Code	Description	Weight Front	Weight Rear	Retail Price
276-001	AUTOMATIC FAN CONTROL WITHOUT DASH SWITCH, NON ENGINE MOUNTED			STD
110-003	CUMMINS SPIN ON FUEL FILTER			STD
118-008	COMBINATION FULL FLOW/BYPASS OIL FILTER			N/C
266-101	900 SQUARE INCH ALUMINUM RADIATOR	15		N/C
103-039	ANTIFREEZE TO -34F, OAT (NITRITE AND SILICATE FREE) EXTENDED LIFE COOLANT			STD
171-007	GATES BLUE STRIPE COOLANT HOSES OR EQUIVALENT			STD
172-001	CONSTANT TENSION HOSE CLAMPS FOR COOLANT HOSES			STD
270-016	RADIATOR DRAIN VALVE			STD
168-002	LOWER RADIATOR GUARD			STD
138-011	PHILLIPS-TEMRO 1000 WATT/115 VOLT BLOCK HEATER	4		\$92.00
140-053	BLACK PLASTIC ENGINE HEATER RECEPTACLE MOUNTED UNDER LH DOOR			N/C
134-001	ALUMINUM FLYWHEEL HOUSING			STD
132-004	ELECTRIC GRID AIR INTAKE WARMER			STD
155-058	DELCO 12V 38MT HD STARTER WITH INTEGRATED MAGNETIC SWITCH			N/C

**Transmission**

342-1KD	ALLISON 3000 EVS AUTOMATIC TRANSMISSION WITH PTO PROVISION	200	60	\$9,059.00
---------	--	-----	----	------------

**Transmission Equipment**

343-331	ALLISON VOCATIONAL PACKAGE 198 - AVAILABLE ON 3000/4000 PRODUCT FAMILIES WITH VOCATIONAL MODEL EVS			N/C
84B-003	ALLISON VOCATIONAL RATING FOR FIRE TRUCK/EMERGENCY VEHICLE APPLICATIONS AVAILABLE WITH ALL PRODUCT FAMILIES			N/C
84C-023	PRIMARY MODE GEARS, LOWEST GEAR 1, START GEAR 1, HIGHEST GEAR 6, AVAILABLE FOR 3000/4000 PRODUCT FAMILIES ONLY			N/C
84D-023	SECONDARY MODE GEARS, LOWEST GEAR 1, START GEAR 1, HIGHEST GEAR 6, AVAILABLE FOR 3000/4000 PRODUCT FAMILIES ONLY			N/C
84E-000	PRIMARY SHIFT SCHEDULE RECOMMENDED BY DTNA AND ALLISON, THIS DEFINED BY ENGINE AND VOCATIONAL USAGE			STD
84F-000	SECONDARY SHIFT SCHEDULE RECOMMENDED BY DTNA AND ALLISON, THIS DEFINED BY ENGINE AND VOCATIONAL USAGE			STD



Prepared for:  
 Jason Bennett  
 NC SHERIFFS ASSOCIATION  
 PO BOX 20049  
 RALEIGH, NC 27619  
 Phone: 919.459.6471



**NCSA Contract#24-08-0421**  
**Freightliner M2-106**

Prepared by:  
 Tony Lyerly  
 EXCEL TRUCK GROUP.  
 4633 EQUIPMENT DRIVE  
 CHARLOTTE, NC 28269  
 Phone: 704-597-1110

Data Code	Description	Weight Front	Weight Rear	Retail Price
84G-000	PRIMARY SHIFT SPEED RECOMMENDED BY DTNA AND ALLISON, THIS DEFINED BY ENGINE AND VOCATIONAL USAGE			STD
84H-000	SECONDARY SHIFT SPEED RECOMMENDED BY DTNA AND ALLISON, THIS DEFINED BY ENGINE AND VOCATIONAL USAGE			STD
84J-000	ENGINE BRAKE RANGE PRESELECT RECOMMENDED BY DTNA AND ALLISON, THIS DEFINED BY ENGINE AND VOCATIONAL USAGE			STD
84K-000	ENGINE BRAKE RANGE ALTERNATE PRESELECT RECOMMENDED BY DTNA AND ALLISON, THIS DEFINED BY ENGINE AND VOCATIONAL USAGE			STD
84N-200	FUEL SENSE 2.0 DISABLED - PERFORMANCE - TABLE BASED			STD
84U-000	DRIVER SWITCH INPUT - DEFAULT - NO SWITCHES			STD
353-073	QUICKFIT BODY LIGHTING CONNECTOR UNDER CAB, WITH CAP			\$125.00
34C-011	ELECTRONIC TRANSMISSION WIRING TO CUSTOMER INTERFACE CONNECTOR			\$125.00
341-018	MAGNETIC PLUGS, ENGINE DRAIN, TRANSMISSION DRAIN, AXLE(S) FILL AND DRAIN			STD
345-003	PUSH BUTTON ELECTRONIC SHIFT CONTROL, DASH MOUNTED			\$254.00
97G-004	TRANSMISSION PROGNOSTICS - ENABLED 2013			N/C
370-015	WATER TO OIL TRANSMISSION COOLER, IN RADIATOR END TANK			STD
346-003	TRANSMISSION OIL CHECK AND FILL WITH ELECTRONIC OIL LEVEL CHECK			N/C
35T-001	SYNTHETIC TRANSMISSION FLUID (TES-295 COMPLIANT)			STD

**Front Axle and Equipment**

400-1A6	DETROIT DA-F-12.0-3 12,000# FF1 71.5 KPI/3.74 DROP SINGLE FRONT AXLE			STD
402-049	MERITOR 16.5X5 Q+ CAST SPIDER CAM FRONT BRAKES, DOUBLE ANCHOR, FABRICATED SHOES			\$242.00
403-043	2011/2013-FMVSS 121 RSD FRONT BRAKE LINING			\$19.00
419-001	CAST IRON OUTBOARD FRONT BRAKE DRUMS			STD
427-001	FRONT BRAKE DUST SHIELDS	5		\$102.00
409-006	FRONT OIL SEALS			STD



Prepared for:  
 Jason Bennett  
 NC SHERIFFS ASSOCIATION  
 PO BOX 20049  
 RALEIGH, NC 27619  
 Phone: 919.459.6471



**NCSA Contract#24-08-0421**  
**Freightliner M2-106**

Prepared by:  
 Tony Lyerly  
 EXCEL TRUCK GROUP.  
 4633 EQUIPMENT DRIVE  
 CHARLOTTE, NC 28269  
 Phone: 704-597-1110

Data Code	Description	Weight Front	Weight Rear	Retail Price
408-001	VENTED FRONT HUB CAPS WITH WINDOW, CENTER AND SIDE PLUGS - OIL			STD
416-022	STANDARD SPINDLE NUTS FOR ALL AXLES			STD
405-002	MERITOR AUTOMATIC FRONT SLACK ADJUSTERS			STD
536-050	TRW THP-60 POWER STEERING			STD
539-003	POWER STEERING PUMP			STD
534-015	2 QUART SEE THROUGH POWER STEERING RESERVOIR			STD
40T-003	SYNTHETIC 40/50W FRONT AXLE LUBE			\$26.00
<b>Front Suspension</b>				
620-1F0	12,000# DUAL TAPERLEAF FRONT SUSPENSION	42		\$57.00
619-005	MAINTENANCE FREE RUBBER BUSHINGS - FRONT SUSPENSION			STD
410-001	FRONT SHOCK ABSORBERS			STD
<b>Rear Axle and Equipment</b>				
420-051	RS-23-160 23,000# R-SERIES SINGLE REAR AXLE		180	\$872.00
421-538	5.38 REAR AXLE RATIO			N/C
424-001	IRON REAR AXLE CARRIER WITH STANDARD AXLE HOUSING			STD
386-073	MXL 17T MERITOR EXTENDED LUBE MAIN DRIVELINE WITH HALF ROUND YOKES			\$141.00
423-019	MERITOR 16.5X8.62 Q+ CAST SPIDER CAM REAR BRAKES, DOUBLE ANCHOR, FABRICATED SHOES			\$125.00
433-043	2011/2013-FMVSS 121 RSD REAR BRAKE LININGS			N/C
434-011	BRAKE CAMS AND CHAMBERS ON FORWARD SIDE OF DRIVE AXLE(S)			N/C
451-023	CONMET CAST IRON REAR BRAKE DRUMS			\$27.00
440-006	REAR OIL SEALS			STD
426-074	HALDEX GOLDSEAL LONGSTROKE 1-DRIVE AXLE SPRING PARKING CHAMBERS			\$20.00
428-002	MERITOR AUTOMATIC REAR SLACK ADJUSTERS			STD
41T-002	CURRENT AVAILABLE SYNTHETIC 75W-90 REAR AXLE LUBE			STD
<b>Rear Suspension</b>				
622-003	23,000# FLAT LEAF SPRING REAR SUSPENSION WITH HELPER AND RADIUS ROD		120	(\$1,145.00)
621-001	SPRING SUSPENSION - NO AXLE SPACERS			N/C





Prepared for:  
 Jason Bennett  
 NC SHERIFFS ASSOCIATION  
 PO BOX 20049  
 RALEIGH, NC 27619  
 Phone: 919.459.6471



**NCSA Contract#24-08-0421**  
**Freightliner M2-106**

Prepared by:  
 Tony Lyerly  
 EXCEL TRUCK GROUP.  
 4633 EQUIPMENT DRIVE  
 CHARLOTTE, NC 28269  
 Phone: 704-597-1110

Data Code	Description	Weight Front	Weight Rear	Retail Price
431-001	STANDARD AXLE SEATS IN AXLE CLAMP GROUP			N/C
623-005	FORE/AFT CONTROL RODS			N/C
<b>Pusher / Tag Equipment</b>				
429-998	NO PUSHER/TAG BRAKE DUST SHIELDS			STD
<b>Brake System</b>				
018-002	AIR BRAKE PACKAGE			STD
490-1AU	WABCO 4S/4M ABS WITH TRACTION CONTROL WITH ATC SHUT OFF SWITCH			\$388.00
871-001	REINFORCED NYLON, FABRIC BRAID AND WIRE BRAID CHASSIS AIR LINES			STD
904-001	FIBER BRAID PARKING BRAKE HOSE			STD
412-001	STANDARD BRAKE SYSTEM VALVES			STD
46D-002	STANDARD AIR SYSTEM PRESSURE PROTECTION SYSTEM			STD
413-002	STD U.S. FRONT BRAKE VALVE			STD
432-003	RELAY VALVE WITH 5-8 PSI CRACK PRESSURE, NO REAR PROPORTIONING VALVE			STD
480-009	BW AD-9 BRAKE LINE AIR DRYER WITH HEATER	20		N/C
479-012	AIR DRYER MOUNTED UNDER HOOD			N/C
460-001	STEEL AIR BRAKE RESERVOIRS			STD
477-006	BW DV-2 AUTO DRAIN VALVE WITHOUT HEATER ON ALL TANK(S)			\$82.00
<b>Trailer Connections</b>				
481-071	12 FOOT COILED TRAILER AIR HOSE WITH 12 INCH TRACTOR, 12 INCH TRAILER LEADS	12		\$5.00
476-001	18 INCH STAINLESS STEEL SLIDE BAR WITH SPRING TYPE TRAILER AIR HOSE HANGER	2		N/C
484-006	COMBINATION DUMMY GLAD HANDS AND LIGHT PLUG HOLDER			N/C
296-010	PRIMARY CONNECTOR/RECEPTACLE WIRED FOR SEPARATE STOP/TURN, ABS CENTER PIN POWERED THROUGH IGNITION			N/C
297-132	SAE J560 7-WAY PRIMARY TRAILER CABLE RECEPTACLE MOUNTED BACK OF CAB/BACK OF SLEEPER			N/C
308-020	SUPPLEMENTAL TRAILER WIRING WITH CENTER PIN IGNITION			\$11.00
331-013	SUPPLEMENTAL ISO 3731 7-WAY RECEPTACLE LOCATED WITH PRIMARY RECEPTACLE BACK OF CAB/BACK OF SLEEPER			\$67.00
1AZ-007	INBOARD FLAG BRACKET LOCATED AT BACK OF CAB/BACK OF SLEEPER			N/C



Prepared for:  
 Jason Bennett  
 NC SHERIFFS ASSOCIATION  
 PO BOX 20049  
 RALEIGH, NC 27619  
 Phone: 919.459.6471



**NCSA Contract#24-08-0421**  
**Freightliner M2-106**

Prepared by:  
 Tony Lyerly  
 EXCEL TRUCK GROUP  
 4633 EQUIPMENT DRIVE  
 CHARLOTTE, NC 28269  
 Phone: 704-597-1110

Data Code	Description	Weight Front	Weight Rear	Retail Price
310-081	12 FOOT DETACHABLE COILED PRIMARY TRAILER ELECTRICAL CABLE WITH SAE J560 CONNECTOR WITH 12 INCH TRACTOR, 12 INCH TRAILER LEADS	12		\$25.00
309-002	12 FOOT DETACHABLE STRAIGHT SUPPLEMENTAL TRAILER ELECTRICAL CABLE; ISO 3731 7-WAY	10		\$57.00

**Wheelbase & Frame**

	545-482	4825MM (190 INCH) WHEELBASE			N/C
	546-100	11/32X3-1/2X10-3/16 INCH STEEL FRAME (8.73MMX258.8MM/0.344X10.19 INCH) 120KSI	50	100	\$135.00
N	552-140	950MM (37 INCH) REAR FRAME OVERHANG			N/C
	55W-003	FRAME OVERHANG RANGE: 31 INCH TO 40 INCH	30	-120	N/C
	AC8-99D	CALC'D BACK OF CAB TO REAR SUSP C/L (CA) : 77.17 in			
	AE8-99D	CALCULATED EFFECTIVE BACK OF CAB TO REAR SUSPENSION C/L (CA) : 72.97 in			
	AE4-99D	CALC'D FRAME LENGTH - OVERALL : 266.34 in			
	FSS-0LH	CALCULATED FRAME SPACE LH SIDE : 171.46 in			N/C
	FSS-0RH	CALCULATED FRAME SPACE RH SIDE : 90.96 in			N/C
	553-002	FLANGED TAPERED END OF FRAME			N/C
	550-001	FRONT CLOSING CROSSMEMBER			STD
	559-001	STANDARD WEIGHT ENGINE CROSSMEMBER			STD
	561-001	STANDARD CROSSMEMBER BACK OF TRANSMISSION			STD
	562-001	STANDARD MIDSHIP #1 CROSSMEMBER(S)			STD
	572-020	INVERTED U TRACTOR CROSSMEMBER		10	\$20.00
	565-001	STANDARD SUSPENSION CROSSMEMBER			STD

**Chassis Equipment**

	674-001	LH BACK OF CAB ACCESS	5	5	N/C
	592-053	14 INCH (350MM) DECK PLATE FLUSH MOUNTED BETWEEN RAILS	5	5	N/C
	556-1AR	THREE-PIECE 14 INCH CHROMED STEEL BUMPER WITH COLLAPSIBLE ENDS	30		\$370.00
	558-001	FRONT TOW HOOKS - FRAME MOUNTED	15		\$74.00
	574-011	SINGLE LICENSE PLATE BUMPER MOUNTING ON LH SIDE			STD
	585-042	BETTS B-25 PAINTED MUDFLAP BRACKETS		15	N/C
	590-001	BLACK MUDFLAPS		15	N/C



Prepared for:  
 Jason Bennett  
 NC SHERIFFS ASSOCIATION  
 PO BOX 20049  
 RALEIGH, NC 27619  
 Phone: 919.459.6471



**NCSA Contract#24-08-0421**  
**Freightliner M2-106**

Prepared by:  
 Tony Lyerly  
 EXCEL TRUCK GROUP  
 4633 EQUIPMENT DRIVE  
 CHARLOTTE, NC 28269  
 Phone: 704-597-1110

Data Code	Description	Weight Front	Weight Rear	Retail Price
586-024	FENDER AND FRONT OF HOOD MOUNTED FRONT MUDFLAPS			STD
551-007	GRADE 8 THREADED HEX HEADED FRAME FASTENERS			STD
44Z-002	EXTERIOR HARNESSSES WRAPPED IN ABRASION TAPE			STD
<b>Fifth Wheel</b>				
578-1W2	FONTAINE 7000 SERIES 7PML FLAT PLATE MOUNT STATIONARY FIFTH WHEEL	30	345	(\$69.00)
577-203	FIFTH WHEEL 203MM (08.0 INCHES) AHEAD OF SUSPENSION CENTERLINE			N/C
582-007	184MM (7.25 INCH) FIFTH WHEEL HEIGHT			N/C
570-004	PLATE MOUNT - FIFTH WHEEL MOUNTING			N/C
579-003	SIDE LEFT FIFTH WHEEL RELEASE			N/C
<b>Fuel Tanks</b>				
206-192	50 GALLON/189 LITER RECTANGULAR ALUMINUM FUEL TANK - RH	20	15	\$607.00
204-998	NO LH FUEL TANK	-60	-20	(\$444.00)
218-005	RECTANGULAR FUEL TANK(S)			STD
215-005	PLAIN ALUMINUM/PAINTED STEEL FUEL/HYDRAULIC TANK(S) WITH PAINTED BANDS			STD
212-007	FUEL TANK(S) FORWARD			STD
664-001	PLAIN STEP FINISH			STD
205-001	FUEL TANK CAP(S)			STD
122-1J1	DETROIT FUEL/WATER SEPARATOR WITH WATER IN FUEL SENSOR, HAND PRIMER AND 12 VOLT PREHEATER"	-5		\$59.00
216-020	EQUIFLO INBOARD FUEL SYSTEM			STD
202-016	HIGH TEMPERATURE REINFORCED NYLON FUEL LINE			STD
<b>Tires</b>				
093-1G4	MICHELIN XZE2 11R22.5 14 PLY RADIAL FRONT TIRES	12		(\$134.00)
094-2DE	MICHELIN X MULTI ENERGY D 11R22.5 14 PLY RADIAL REAR TIRES		80	\$56.00
<b>Hubs</b>				
418-060	CONMET PRESET PLUS PREMIUM IRON FRONT HUBS			STD
450-060	CONMET PRESET PLUS PREMIUM IRON REAR HUBS			STD



Prepared for:  
 Jason Bennett  
 NC SHERIFFS ASSOCIATION  
 PO BOX 20049  
 RALEIGH, NC 27619  
 Phone: 919.459.6471



**NCSA Contract#24-08-0421**  
**Freightliner M2-106**

Prepared by:  
 Tony Lyerly  
 EXCEL TRUCK GROUP  
 4633 EQUIPMENT DRIVE  
 CHARLOTTE, NC 28269  
 Phone: 704-597-1110

Data Code	Description	Weight Front	Weight Rear	Retail Price
<b>Wheels</b>				
502-735	ACCURIDE 43644 ACCU-LITE 22.5X8.25 10-HUB PILOT 5.79 INSET ALUMINUM DISC FRONT WHEELS	-64		\$322.00
505-736	ACCURIDE 43644 ACCU-LITE 22.5X8.25 10-HUB PILOT ALUMINUM DISC REAR WHEELS		-128	\$644.00
496-011	FRONT WHEEL MOUNTING NUTS			STD
497-011	REAR WHEEL MOUNTING NUTS			STD
<b>Cab Exterior</b>				
829-079	154 INCH BBC HIGH-ROOF ALUMINUM CONVENTIONAL CREW CAB	430	250	\$12,419.00
650-008	AIR CAB MOUNTING			\$97.00
648-002	NONREMOVABLE BUGSCREEN MOUNTED BEHIND GRILLE			\$36.00
678-998	NO GRAB HANDLES			(\$55.00)
646-023	HOOD MOUNTED CHROMED PLASTIC GRILLE			\$159.00
65X-003	CHROME HOOD MOUNTED AIR INTAKE GRILLE			\$43.00
644-004	FIBERGLASS HOOD			STD
690-002	TUNNEL/FIREWALL LINER			STD
726-002	DUAL ELECTRIC HORNS			\$10.00
575-001	REAR LICENSE PLATE MOUNT END OF FRAME			STD
312-088	LED HEADLIGHT ASSEMBLY AND INCANDESCENT MARKER/TURN LAMP WITH CHROME BEZEL			\$848.00
302-047	LED AERODYNAMIC MARKER LIGHTS			STD
311-001	DAYTIME RUNNING LIGHTS			STD
294-042	FREIGHTLINER LED FLANGE MOUNTED STOP/TAIL/TURN LIGHTS WITH SEPARATE INCANDESCENT BACKUP LIGHTS		5	\$120.00
300-015	STANDARD FRONT TURN SIGNAL LAMPS			STD
744-1BC	DUAL WEST COAST BRIGHT FINISH HEATED MIRRORS WITH LH AND RH REMOTE			\$133.00
797-001	DOOR MOUNTED MIRRORS			STD
796-001	102 INCH EQUIPMENT WIDTH			STD
743-204	LH AND RH 8 INCH BRIGHT FINISH CONVEX MIRRORS MOUNTED UNDER PRIMARY MIRRORS			N/C
729-001	STANDARD SIDE/REAR REFLECTORS			STD
73A-002	REAR REFLECTIVE DEVICE			N/C
768-043	63X14 INCH TINTED REAR WINDOW			STD
661-003	TINTED DOOR GLASS LH AND RH WITH TINTED NON-OPERATING WING WINDOWS			STD



Prepared for:  
 Jason Bennett  
 NC SHERIFFS ASSOCIATION  
 PO BOX 20049  
 RALEIGH, NC 27619  
 Phone: 919.459.6471



**NCSA Contract#24-08-0421**  
**Freightliner M2-106**

Prepared by:  
 Tony Lyerly  
 EXCEL TRUCK GROUP  
 4633 EQUIPMENT DRIVE  
 CHARLOTTE, NC 28269  
 Phone: 704-597-1110

Data Code	Description	Weight Front	Weight Rear	Retail Price
654-011	RH AND LH ELECTRIC POWERED WINDOWS			\$162.00
663-013	1-PIECE SOLAR GREEN GLASS WINDSHIELD			STD
659-019	2 GALLON WINDSHIELD WASHER RESERVOIR WITHOUT FLUID LEVEL INDICATOR, FRAME MOUNTED			STD
<b>Cab Interior</b>				
055-017	PROFESSIONAL TRIM PACKAGE			STD
707-105	MIST AND CARBON CLOTH INTERIOR "PROFESSIONAL"			STD
70K-016	CARBON WITH BASE BLACK ACCENT			STD
706-013	MOLDED PLASTIC DOOR PANEL			STD
708-013	MOLDED PLASTIC DOOR PANEL			STD
772-006	BLACK MATS WITH SINGLE INSULATION			STD
785-035	ASH CUP AND (1)LIGHTER,(1)DASH MOUNTED DUAL USB-C OUTLET			\$42.00
691-001	FORWARD ROOF MOUNTED CONSOLE			STD
693-019	LH AND RH DOOR STORAGE POCKETS INTEGRATED INTO MOLDED DOOR PANELS			STD
738-021	DIGITAL ALARM CLOCK IN DRIVER DISPLAY			STD
742-007	(2) CUP HOLDERS LH AND RH DASH			STD
680-029	M2/SD DASH			STD
720-002	2-1/2 LB. FIRE EXTINGUISHER	5		\$37.00
700-002	HEATER, DEFROSTER AND AIR CONDITIONER			STD
701-001	STANDARD HVAC DUCTING			STD
703-005	MAIN HVAC CONTROLS WITH RECIRCULATION SWITCH			STD
170-015	STANDARD HEATER PLUMBING			STD
130-041	VALEO HEAVY DUTY A/C REFRIGERANT COMPRESSOR			STD
702-002	BINARY CONTROL, R-134A			STD
739-033	STANDARD INSULATION			STD
285-013	SOLID-STATE CIRCUIT PROTECTION AND FUSES			STD
280-007	12V NEGATIVE GROUND ELECTRICAL SYSTEM			STD
324-1B2	PREMIUM LED CAB LIGHTING			(\$10.00)
787-998	NO SECURITY DEVICE			(\$300.00)
657-001	DOOR LOCKS AND IGNITION SWITCH KEYED THE SAME			STD
78G-004	KEY QUANTITY OF 4			\$18.00
655-005	LH AND RH ELECTRIC DOOR LOCKS			STD



Prepared for:  
 Jason Bennett  
 NC SHERIFFS ASSOCIATION  
 PO BOX 20049  
 RALEIGH, NC 27619  
 Phone: 919.459.6471



**NCSA Contract#24-08-0421**  
**Freightliner M2-106**

Prepared by:  
 Tony Lyerly  
 EXCEL TRUCK GROUP  
 4633 EQUIPMENT DRIVE  
 CHARLOTTE, NC 28269  
 Phone: 704-597-1110

Data Code	Description	Weight Front	Weight Rear	Retail Price
722-028	TRIANGULAR REFLECTORS KIT WITHOUT FLARES SHIPPED LOOSE IN CAB	10		\$24.00
756-336	BASIC ISRI HIGH BACK NON SUSPENSION DRIVERS SEAT W/FORE & AFT ADJUSTMENT			STD
760-209	SEATS INC 911 UNIVERSAL SERIES HIGH BACK AIR SUSPENSION PASSENGER SEAT	45	20	\$382.00
762-086	SEATS INC 911 UNIVERSAL SCBA NON SUSPENSION LH AND RH REAR PASSENGER SEATS WITH UNDER SEAT STORAGE AND NFPA 1901-2009/2016 COMPLIANT SEAT SENSOR	140	40	\$1,109.00
711-004	LH AND RH INTEGRAL DOOR PANEL ARMRESTS			STD
758-1AK	BLACK VINYL DRIVER SEAT COVER			STD
761-150	BLACK WITH GRAY INSERT MORDURA CLOTH PASSENGER SEAT			\$34.00
755-1AK	BLACK VINYL REAR PASSENGER SEAT COVER			N/C
N 763-102	HIGH VISIBILITY ORANGE SEAT BELTS			\$52.00
532-002	ADJUSTABLE TILT AND TELESCOPING STEERING COLUMN			STD
540-044	4-SPOKE 18 INCH (450MM) BLACK STEERING WHEEL WITH SWITCHES			STD
765-002	DRIVER AND PASSENGER INTERIOR SUN VISORS			STD

**Instruments & Controls**

734-022	FULLY CONFIGURABLE CENTER INSTRUMENT PANELS			(\$55.00)
87L-001	ENGINE REMOTE INTERFACE WITH PARK BRAKE INTERLOCK			N/C
870-001	BLACK GAUGE BEZELS			STD
486-001	LOW AIR PRESSURE INDICATOR LIGHT AND AUDIBLE ALARM			STD
840-001	DUAL NEEDLE PRIMARY AND SECONDARY AIR PRESSURE GAUGE			STD
198-025	INTAKE MOUNTED AIR RESTRICTION INDICATOR WITHOUT GRADUATIONS			STD
149-998	NO SPEED CONTROL			(\$55.00)
156-007	KEY OPERATED IGNITION SWITCH AND INTEGRAL START POSITION; 4 POSITION OFF/RUN/START/ACCESSORY			STD
811-044	PREMIUM INSTRUMENT CLUSTER WITH 5.0 INCH TFT COLOR DISPLAY			STD
81B-003	DIGITAL PANEL LAMP DIMMER SWITCH IN DRIVER DISPLAY			STD



Prepared for:  
 Jason Bennett  
 NC SHERIFFS ASSOCIATION  
 PO BOX 20049  
 RALEIGH, NC 27619  
 Phone: 919.459.6471



**NCSA Contract#24-08-0421**  
**Freightliner M2-106**

Prepared by:  
 Tony Lyerly  
 EXCEL TRUCK GROUP  
 4633 EQUIPMENT DRIVE  
 CHARLOTTE, NC 28269  
 Phone: 704-597-1110

Data Code	Description	Weight Front	Weight Rear	Retail Price
160-038	HEAVY DUTY ONBOARD DIAGNOSTICS INTERFACE CONNECTOR LOCATED BELOW LH DASH			STD
844-001	2 INCH ELECTRIC FUEL GAUGE			STD
148-072	ENGINE REMOTE INTERFACE WITH ONE OR MORE SET SPEEDS			\$134.00
48H-001	QUICKFIT POWERTRAIN INTERFACE CONNECTOR LOCATED BETWEEN SEATS WITH CAPS			\$77.00
4C0-998	NO ADDITIONAL EXTRA SWITCH ACCUATORS			STD
48C-001	QUICKFIT PROGRAMMABLE INTERFACE CONNECTOR(S) BETWEEN SEATS WITH CAP			N/C
163-014	ENGINE REMOTE INTERFACE CONNECTOR AT POWERTRAIN INTERFACE CONNECTOR			N/C
856-001	ELECTRICAL ENGINE COOLANT TEMPERATURE GAUGE			STD
864-001	2 INCH TRANSMISSION OIL TEMPERATURE GAUGE			\$30.00
867-004	ELECTRONIC OUTSIDE TEMPERATURE SENSOR DISPLAY IN DRIVER MESSAGE CENTER			STD
830-017	ENGINE AND TRIP HOUR METERS INTEGRAL WITHIN DRIVER DISPLAY			STD
N 372-123	PTO CONTROLS FOR ENHANCED VEHICLE ELECTRIC/ELECTRONIC ARCHITECTURE			\$40.00
736-998	NO OBSTACLE DETECTION SYSTEM			(\$4,324.00)
72J-998	NO DR ASSIST SYSTEM			(\$32.00)
49B-004	ELECTRONIC STABILITY CONTROL			N/C
73B-998	NO LANE DEPARTURE WARNING SYSTEM			(\$1,080.00)
852-002	ELECTRIC ENGINE OIL PRESSURE GAUGE			STD
35M-010	QUICKFIT PROGRAMMABLE INTERFACE MODULE	10		\$154.00
746-135	AM/FM/WB WORLD TUNER RADIO WITH SIRIUSXM, BLUETOOTH, IPOD INTERFACE, USB AND AUXILIARY INPUTS, J1939	10		N/C
747-001	DASH MOUNTED RADIO			STD
750-002	(2) RADIO SPEAKERS IN CAB			STD
753-998	NO AM/FM RADIO ANTENNA			(\$47.00)
748-006	POWER AND GROUND WIRING PROVISION OVERHEAD			\$18.00
749-001	ROOF/OVERHEAD CONSOLE CB RADIO PROVISION			\$55.00



Prepared for:  
 Jason Bennett  
 NC SHERIFFS ASSOCIATION  
 PO BOX 20049  
 RALEIGH, NC 27619  
 Phone: 919.459.6471



**NCSA Contract#24-08-0421**  
**Freightliner M2-106**

Prepared by:  
 Tony Lyerly  
 EXCEL TRUCK GROUP.  
 4633 EQUIPMENT DRIVE  
 CHARLOTTE, NC 28269  
 Phone: 704-597-1110

Data Code	Description	Weight Front	Weight Rear	Retail Price
75W-002	SHARKFIN MULTI-BAND ANTENNA: AM/FM/WEATHERBAND, WIFI/BLUETOOTH, SDAR/SIRIUSXM, GNSS/GPS			\$108.00
78C-003	INTEROPERABLE SDAR ANTENNA			\$85.00
74D-006	STANDARD RADIO WIRING WITH STEERING WHEEL CONTROLS			STD
810-027	ELECTRONIC MPH SPEEDOMETER WITH SECONDARY KPH SCALE, WITHOUT ODOMETER			STD
817-001	STANDARD VEHICLE SPEED SENSOR			STD
812-001	ELECTRONIC 3000 RPM TACHOMETER			STD
813-1C8	DETROIT CONNECT PLATFORM HARDWARE			STD
6TS-005	TMC RP1226 ACCESSORY CONNECTOR LOCATED BEHIND PASSENGER SIDE REMOVEABLE DASH PANEL			STD
162-002	IGNITION SWITCH CONTROLLED ENGINE STOP			STD
264-033	STEERING WHEEL MOUNTED ELECTRIC HORN CONTROL			STD
482-001	BW TRACTOR PROTECTION VALVE			N/C
883-001	TRAILER HAND CONTROL BRAKE VALVE			N/C
836-015	DIGITAL VOLTAGE DISPLAY INTEGRAL WITH DRIVER DISPLAY			STD
660-008	SINGLE ELECTRIC WINDSHIELD WIPER MOTOR WITH DELAY			STD
304-030	ROTARY HEADLAMP SWITCH, MARKER LIGHTS/HEADLIGHTS SWITCH WITH PULL OUT FOR OPTIONAL FOG/ROAD LAMPS			N/C
882-004	TWO VALVE PARKING BRAKE SYSTEM WITH WARNING INDICATOR			N/C
299-020	SELF CANCELING TURN SIGNAL SWITCH WITH DIMMER, HEADLAMP FLASH, WASH/WIPE/INTERMITTENT			STD
298-046	INTEGRAL ELECTRONIC TURN SIGNAL FLASHER WITH 40 AMP (20 AMP PER SIDE) TRAILER LAMP CAPACITY			STD
<b>Design</b>				
065-000	PAINT: ONE SOLID COLOR			STD
<b>Color</b>				
980-5F6	CAB COLOR A: L0006EY WHITE ELITE EY			STD
986-020	BLACK, HIGH SOLIDS POLYURETHANE CHASSIS PAINT			STD
969-998	NO CAB/BODY EXTERIOR DECALS			STD
963-003	STANDARD E COAT/UNDERCOATING			STD





Prepared for:  
 Jason Bennett  
 NC SHERIFFS ASSOCIATION  
 PO BOX 20049  
 RALEIGH, NC 27619  
 Phone: 919.459.6471



**NCSA Contract#24-08-0421**  
**Freightliner M2-106**

Prepared by:  
 Tony Lyerly  
 EXCEL TRUCK GROUP  
 4633 EQUIPMENT DRIVE  
 CHARLOTTE, NC 28269  
 Phone: 704-597-1110

Data Code	Description	Weight Front	Weight Rear	Retail Price
<b>Certification / Compliance</b>				
996-001	U.S. FMVSS CERTIFICATION, EXCEPT SALES CABS AND GLIDER KITS			STD

<b>Sales Programs</b>				
NO SALES PROGRAMS HAVE BEEN SELECTED				

**TOTAL VEHICLE SUMMARY**

**Adjusted List Price**

Adjusted List Price \*\* \$156,642.00

**Weight Summary**

	Weight Front	Weight Rear	Total Weight
Factory Weight <sup>+</sup>	7494 lbs	4452 lbs	11946 lbs
Total Weight <sup>+</sup>	7494 lbs	4452 lbs	11946 lbs

**ITEMS NOT INCLUDED IN ADJUSTED LIST PRICE**

**Other Factory Charges**

PMV-024	GHG24 SURCHARGE - CUMMINS	\$555.00
PNV-998	NO CARB24 PRICING IMPACT	N/C
RAC-42N	M2/SD PLUS ESCALATOR	\$750.00
RAG-020	CUMMINS TARIFF CHARGE - \$205	\$205.00
RAU-025	MY25 ESCALATOR	\$1,500.00
RFY-022	FRONT TIRE SURCHARGE	\$130.00
RFU-022	REAR TIRE SURCHARGE	\$260.00
P73-2FT	STANDARD DESTINATION CHARGE	\$3,375.00



Prepared for:  
 Jason Bennett  
 NC SHERIFFS ASSOCIATION  
 PO BOX 20049  
 RALEIGH, NC 27619  
 Phone: 919.459.6471



**NCSA Contract#24-08-0421**  
**Freightliner M2-106**

Prepared by:  
 Tony Lyerly  
 EXCEL TRUCK GROUP.  
 4633 EQUIPMENT DRIVE  
 CHARLOTTE, NC 28269  
 Phone: 704-597-1110

**Extended Warranty**

WAG-073	TOWING: 6 MONTHS/UNLIMITED MILES/KM EXTENDED TOWING COVERAGE \$750 CAP FEX APPLIES	\$115.00
	Currency Exchange Rate	1.0000
	Total Extended Warranty (Local Currency)	\$115.00

(+) Weights shown are estimates only.

If weight is critical, contact Customer Application Engineering.

(\*\*) Prices shown do not include taxes, fees, etc... "Net Equipment Selling Price" is located on the Quotation Details Proposal Report.

(\*\*\*) All cost increases for major components (Engines, Transmissions, Axles, Front and Rear Tires) and government mandated requirements, tariffs, and raw material surcharges will be passed through and added to factory invoices.





# City of High Point

Municipal Office Building  
211 S. Hamilton Street  
High Point, NC 27260

## Master

**File Number: 2024-037**

**File ID:** 2024-037

**Type:** Miscellaneous Item

**Status:** To Be Introduced

**Version:** 1

**Reference:**

**In Control:** Finance Committee

**File Created:** 01/26/2024

**File Name:**

**Final Action:**

**Title:** Consideration of a Contract with Triangle Grading and Paving, Inc.  
City Council is requested to approve a contract award to Triangle Grading and Paving, Inc. in the amount of \$4,299,385.30 for the Samet Drive Extension Project, adopt a capital project ordinance amendment, and authorize the appropriate City Official(s) to execute all necessary documents.

**Notes:**

**Sponsors:**

**Enactment Date:**

**Attachments:** Contract - Triangle Grading and Paving, Inc - Samet Drive Extension

**Enactment Number:**

**Contact Name:**

**Hearing Date:**

**Drafter Name:** sandra.keeney@highpointnc.gov

**Effective Date:**

### History of Legislative File

Ver- sion:	Acting Body:	Date:	Action:	Sent To:	Due Date:	Return Date:	Result:

# CITY OF HIGH POINT

## AGENDA ITEM



<b>TITLE:</b> Contract Award; Samet Drive Extension Project	
<b>FROM:</b> Trevor Spencer, Engineering Director	<b>MEETING DATE:</b> February 5, 2024
<b>PUBLIC HEARING:</b> N/A	<b>ADVERTISED DATE/BY:</b> December 8, 2023
<b>ATTACHMENTS:</b> 1. Capital Project Ordinance Amendment 2. Project Exhibit 3. Bid Recommendation Form	

**PURPOSE:** City Council is asked to award a construction contract for the Samet Drive Extension project to Triangle Grading and Paving, Inc.

**BACKGROUND:** The City of High Point is constructing Samet Drive Extension from Penny Road to Wendover Avenue to achieve transportation improvements and accommodate economic development in the surrounding area. The roadway project includes water, sewer, and storm utilities, sidewalks, curb and gutter, a roundabout intersection, turn lanes and traffic signal improvements.

On January 23, 2024, the City received bids for contract ENG2023-003 from the following responsive bidders:

<u>Amount</u>	<u>Contractor</u>
\$4,299,385.30	Triangle Grading and Paving, Inc.
\$4,566,506.76	Smith and Jennings, Inc.
\$5,683,252.96	Smith-Rowe, LLC.
\$5,697,774.50	Atlantic Contracting Company Inc.

The contractor can begin work following award and full contract document execution or issuance of the Notice to Proceed. The contractor will have 365 days to complete all contract construction work.

**BUDGET IMPACT:** A capital project ordinance amendment appropriating two-thirds general obligations bonds is included with this item. Debt service payments for the general obligation bonds will be paid from the city’s general debt service fund.

**RECOMMENDATION/ACTION REQUESTED:** Engineering Services recommends that Council approve the contract award for the Samet Drive Extension project to Triangle Grading and Paving, Inc. for the contract bid amount of \$4,299,385.30, and approve the capital project ordinance amendment.

"AN CAPITAL PROJECT ORDINANCE AMENDMENT  
OF THE CITY OF HIGH POINT, NORTH CAROLINA  
FOR THE SAMET DRIVE EXTENSION PROJECT

Be it ordained by the City Council of the City of High Point, North Carolina, that,  
pursuant to Section 13.2 of Chapter 159 of the General Statutes of North Carolina, the  
following Capital Project Ordinance is hereby adopted:

- Section 1. The City of High Point is constructing Samet Drive Extension from Penny Road to Wendover Avenue to achieve transportation improvements and accommodate economic development in the surrounding area. The roadway project includes water, sewer, and storm utilities, sidewalks, curb and gutter, a roundabout intersection, turn lanes and traffic signal improvements. The project will be paid by two-thirds general obligation bonds.
- Section 2. The following revenue is available to the City of High Point:
- |   |             |
|---|-------------|
| Two-Thirds General Obligation Bond Proceeds | \$4,299,386 |
|---|-------------|
- Section 3. The following amounts are appropriated for the Project:
- |                       |             |
|-----------------------|-------------|
| Samet Drive Extension | \$4,299,386 |
|-----------------------|-------------|
- Section 4. The Financial Services Director is hereby directed to maintain a Capital Project with sufficient detail accounting records to allow compliance with G.S. 159-28 Budgetary accounting for appropriations
- Section 5. Copies of this capital project ordinance shall be made available to the City Manager and the Financial Services Director for direction in carrying out this project."

Adopted by High Point City Council, this the 5th day of February 2024

\_\_\_\_\_  
Cyril Jefferson, Mayor

ATTEST

\_\_\_\_\_  
Sandra Keeney, City Clerk

# Samet Drive Extension Project Exhibit

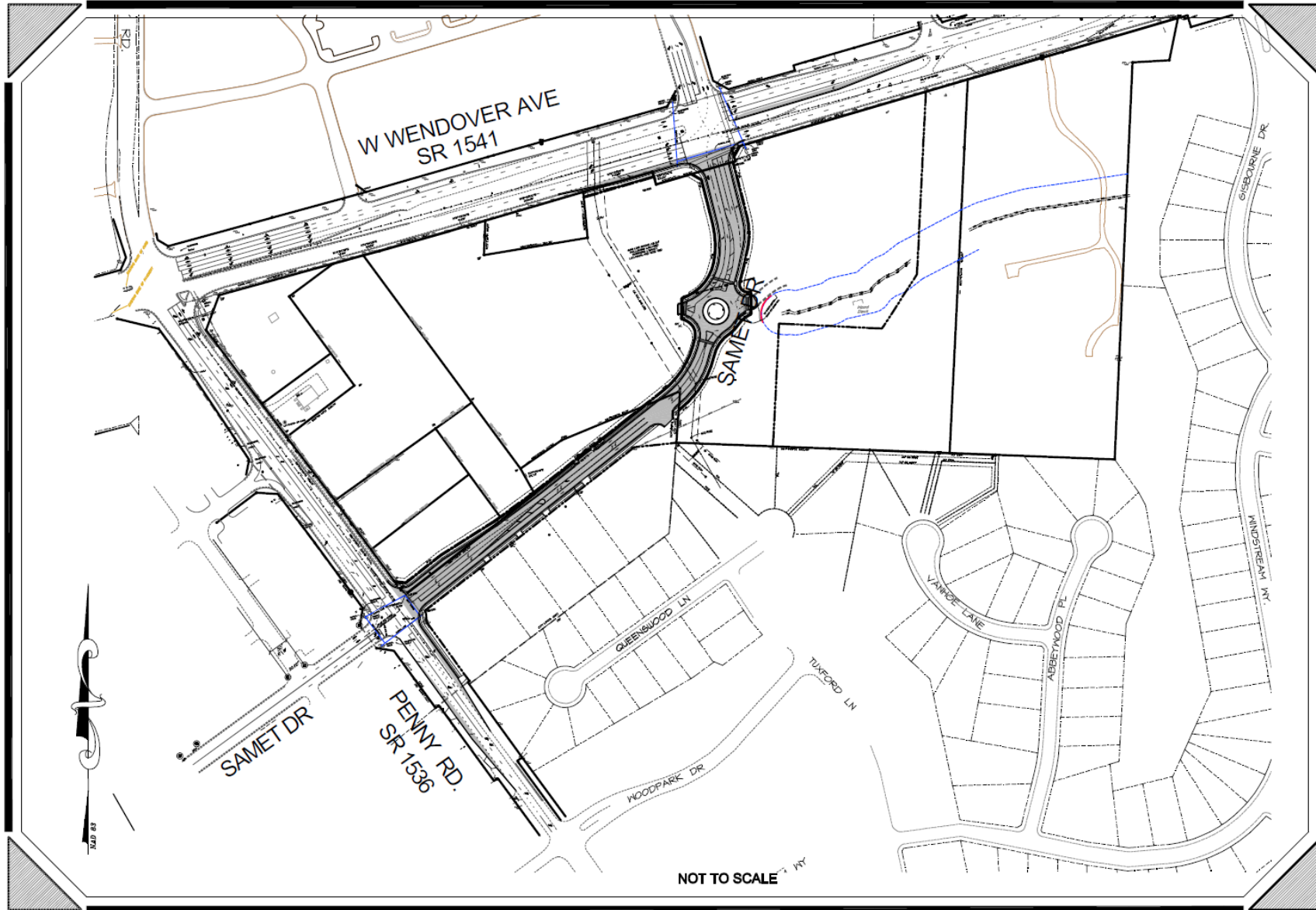

**BID RECOMMENDATION**

DEPARTMENT:

COUNCIL AGENDA DATE:

BID NO.:  CONTRACT NO.:  DATE OPEN:

DESCRIPTION:

PURPOSE:  
The Engineering Services Department recommends approval of contract ENG2023-003 for the Samet Drive Extension project. This includes mobilization, grading, installing water, sewer, storm drain, new roadway construction, curb and gutter, sidewalk, traffic signals, paving, striping the new road and turn lanes.

COMMENTS:  
The City received four responsive bidders:  
Triangle Grading and Paving, Inc.: \$4,299,385.30      Smith and Jennings, Inc.: \$4,566,506.76  
Atlantic Contracting Company Inc. \$5,697,774.50      Smith-Rowe, LLC. \$5,683,252.96

RECOMMEND AWARD TO:  AMOUNT:

JUSTIFICATION:

ACCOUNTING UNIT	ACCOUNT	ACTIVITY	CATEGORY	BUDGETED AMOUNT
401710	533701	401221030605	40202	\$4,299,385.30
TOTAL BUDGETED AMOUNT				

DEPARTMENT HEAD:  Digitally signed by Trevor Spencer Date: 2024.01.25 10:28:12 -05'00' DATE:

The Purchasing Division concurs with recommendation submitted by the  and recommends award to the lowest responsible, responsive bidder  in the amount of

PURCHASING MANAGER:  Digitally signed by Candy E. Harmon Date: 2024.01.25 13:54:33 -05'00' DATE:

Approved for Submission to Council

FINANCIAL SERVICES DIRECTOR:  Digitally signed by Bobby Fitzjohn Date: 2024.01.25 14:13:47 -05'00' DATE:

CITY MANAGER:  DATE:

(For City Council Approval Only)



# City of High Point

Municipal Office Building  
211 S. Hamilton Street  
High Point, NC 27260

## Master

**File Number: 2024-038**

**File ID:** 2024-038

**Type:** Miscellaneous Item

**Status:** To Be Introduced

**Version:** 1

**Reference:**

**In Control:** Finance Committee

**File Created:** 01/26/2024

**File Name:**

**Final Action:**

**Title:** Consideration of a Task Order with Michael Baker International  
City Council is requested to approve a task order with Michael Baker International in the amount of \$275,000 for construction inspection and materials testing services for the Samet Drive Extension project, adopt a capital project ordinance amendment, and authorize the appropriate City Official(s) to execute all necessary documents.

**Notes:**

**Sponsors:**

**Enactment Date:**

**Attachments:** Task Order - Michael Baker International- Samet Drive Extension Inspection and Materials Testing Services

**Enactment Number:**

**Contact Name:**

**Hearing Date:**

**Drafter Name:** sandra.keeney@highpointnc.gov

**Effective Date:**

### History of Legislative File

Ver- sion:	Acting Body:	Date:	Action:	Sent To:	Due Date:	Return Date:	Result:



# CITY OF HIGH POINT

## AGENDA ITEM



<b>TITLE:</b> Samet Drive Extension Project - Construction Inspection and Materials Testing Services	
<b>FROM:</b> Trevor Spencer, Engineering Director	<b>MEETING DATE:</b> February 5, 2024
<b>PUBLIC HEARING:</b> N/A	<b>ADVERTISED DATE/BY:</b> N/A
<b>ATTACHMENTS:</b> 1. Capital Project Ordinance Amendment 2. Bid Recommendation Form	

**PURPOSE:** The Engineering Services Department recommends City Council to approve a task order with Micheal Baker International for construction inspection and materials testing services for the Samet Drive Extension project. Michael Baker International has a master agreement with the City as a prequalified on-call materials testing consultant. Examples of inspections and materials testing that will be provided include soil backfill compaction, asphalt densities, concrete compressive strength of sidewalks and curb and gutter, and monitoring the contractor’s daily construction operations.

**BACKGROUND:** On Wednesday, January 24, 2024 the City of High Point received a proposal for construction inspection and materials testing for contract ENG2023-003.

<u>Consultant</u>	<u>Amount</u>
Michael Baker International	\$275,000.00

The availability date of this task order will be the Notice to Proceed date for the Samet Drive Extension project.

**BUDGET IMPACT:** A capital project ordinance amendment appropriating two-thirds general obligations bonds is included with this item. Debt service payments for the general obligation bonds will be paid from the city’s general debt service fund.

**RECOMMENDATION/ACTION REQUESTED:** Engineering Services recommends approval of the construction inspection and materials testing services, that the appropriate City official and/or employee be authorized to execute all necessary documents to award the task order to Michael Baker International in the amount of \$275,000.00, and approval of the capital project ordinance amendment.

"AN CAPITAL PROJECT ORDINANCE AMENDMENT  
OF THE CITY OF HIGH POINT, NORTH CAROLINA  
FOR INSPECTIONS AND MATERIALS TESTING  
FOR THE SAMET DRIVE EXTENSION PROJECT

Be it ordained by the City Council of the City of High Point, North Carolina, that,  
pursuant to Section 13.2 of Chapter 159 of the General Statutes of North Carolina, the  
following Capital Project Ordinance is hereby adopted:

- Section 1. The City of High Point is constructing Samet Drive Extension from Penny Road to Wendover Avenue to achieve transportation improvements and accommodate economic development in the surrounding area. Construction inspection and materials testing is part of this project. These will be paid by two-thirds general obligation bonds.
- Section 2. The following revenue is available to the City of High Point:
- |   |           |
|---|-----------|
| Two-Thirds General Obligation Bond Proceeds | \$275,000 |
|---|-----------|
- Section 3. The following amounts are appropriated for the Project:
- |  |           |
|--|-----------|
| Samet Drive Extension – Inspection and Materials Testing | \$275,000 |
|--|-----------|
- Section 4. The Financial Services Director is hereby directed to maintain a Capital Project with sufficient detail accounting records to allow compliance with G.S. 159-28 Budgetary accounting for appropriations.
- Section 5. Copies of this capital project ordinance shall be made available to the City Manager and the Financial Services Director for direction in carrying out this project."

Adopted by High Point City Council, this the 5th day of February 2024

\_\_\_\_\_  
Cyril Jefferson, Mayor

ATTEST

\_\_\_\_\_  
Sandra Keeney, City Clerk

**BID RECOMMENDATION**

DEPARTMENT:

COUNCIL AGENDA DATE:

BID NO.:  CONTRACT NO.:  DATE OPEN:

DESCRIPTION:

PURPOSE:

COMMENTS:

RECOMMEND AWARD TO:  AMOUNT:

JUSTIFICATION:

ACCOUNTING UNIT	ACCOUNT	ACTIVITY	CATEGORY	BUDGETED AMOUNT
401710	533701	401221030605	40202	\$275,000.00
TOTAL BUDGETED AMOUNT				

DEPARTMENT HEAD:  Digitally signed by Trevor Spencer Date: 2024.01.25 10:55:06 -05'00' DATE:

The Purchasing Division concurs with recommendation submitted by the  and recommends award to the lowest responsible, responsive bidder  in the amount of

PURCHASING MANAGER:  Digitally signed by Candy E. Harmon Date: 2024.01.25 14:01:00 -05'00' DATE:

Approved for Submission to Council

FINANCIAL SERVICES DIRECTOR:  Digitally signed by Bobby Fitzjohn Date: 2024.01.25 14:15:54 -05'00' DATE:

CITY MANAGER:  DATE:

(For City Council Approval Only)



# City of High Point

Municipal Office Building  
211 S. Hamilton Street  
High Point, NC 27260

## Master

**File Number: 2024-040**

**File ID:** 2024-040

**Type:** Miscellaneous Item

**Status:** To Be Introduced

**Version:** 1

**Reference:**

**In Control:** Finance Committee

**File Created:** 01/29/2024

**File Name:**

**Final Action:**

**Title:** Consideration of Contract with Trademark Properties  
City Council is requested to approve a contract with Trademark Properties in the amount of \$120,000 to perform advisory services for planning, construction and delivery of a new City Hall and associated uses at 405 N. Main Street and authorize the appropriate City Official(s) to execute all necessary documents.

**Notes:**

**Sponsors:**

**Enactment Date:**

**Attachments:** Contract - Trademark Properties

**Enactment Number:**

**Contact Name:**

**Hearing Date:**

**Drafter Name:** sandra.keeney@highpointnc.gov

**Effective Date:**

### History of Legislative File

Ver- sion:	Acting Body:	Date:	Action:	Sent To:	Due Date:	Return Date:	Result:

# CITY OF HIGH POINT

## AGENDA ITEM



<b>TITLE:</b> Professional Services Contract – TradeMark Properties – City Hall project	
<b>FROM:</b> Eric Olmedo, Assistant City Manager	<b>MEETING DATE:</b> February 5, 2024
<b>PUBLIC HEARING:</b> N/A	<b>ADVERTISED DATE/BY:</b> N/A
<b>ATTACHMENTS:</b> Scope of Services	

**PURPOSE:**

To consider acceptance of a proposal from TradeMark Properties to perform advisory services for planning, construction and delivery of a new City Hall and associated uses at 405 N. Main Street.

**BACKGROUND:**

On September 18, 2023 City Council authorized the purchase of 405 N. Main Street for the development of a new City Hall facility. There are multiple opportunities to achieve the overall highest investment in the downtown area, and having a thoughtful development plan is critical to guide the decisions around activating this area. Staff must fully understand the implications of government, multi-family, entertainment, retail, office, and parking uses and how they work together to provide recommendations to the City Council based on market feasibility, financial stewardship, and development best practices.

TradeMark Properties will provide guidance and insight by reviewing all third-party reports and future City plans, speaking with local landlords, real property owners, developers, and stakeholders to gain insight into High Point’s market dynamics. Trademark will provide recommendations regarding the best mix of multifamily, office, retail, and entertainment options in addition to governmental uses. TradeMark will develop clarity around parking needs for each use, considering the stadium and other announced projects in the immediate area. Trademark will advise on City zoning and planning conditions, engage a land planning/architectural professional to develop and deliver potential development scenarios based on the above potential uses, and create a massing study to attract a partner developer.

The final component of the work is to provide potential financing options, engage with a parking owner/operator, engage an estimator with a commercial General Contractor to provide a rough cost estimate, provide basic underwriting for each potential use, and provide recommendations for how the City might incent development.

**BUDGET IMPACT:** Funding is available in the General Fund budget.

**RECOMENDATION /ACTION REQUESTED:**

City Council is requested to authorize the City Manager to enter into a contract with Trademark Properties in the amount of \$120,000 and to authorize the appropriate city official to execute all necessary documents.



January 12, 2024

Ms. Tasha Logan Ford  
City Manager  
City of High Point

Re: City Hall Project

Dear Tasha and team,

TradeMark Properties is pleased to offer advisory services to the city of High Point for the next steps in the planning, construction, and delivery of a vibrant downtown complex that includes a new City Hall. We are confident in our ability to provide significant value to the organization as it embarks on this exciting project. We understand that initial studies for land planning, parking, and various uses have been completed and are helpful in advancing the discussions around feasibility. The next steps will lead the City to make concrete decisions to confirm ownership structure, partner or JV opportunities, ground leases, and/or a sale of segments of the parcel. This work will result in an agreement to move forward with the project based on the City's goals and based on best and highest uses.

***Phase 1 Market Planning and Development Guidance:***

The City has multiple options to achieve optimum development based on the overall highest investment in the downtown area and impact on the surrounding neighborhood. While the construction and occupancy of a new city hall is a natural catalyst, the decisions around activating this area of Main Street and the area around the stadium are critical. The City must understand the implications of multi-family, entertainment, retail, office, and parking uses. The ability to form recommendations to the City Council will be based on clear market feasibility, financial stewardship, and thoughtful development.

TradeMark will provide:

- Guidance and insight into the decision-making process, including but not limited to reviewing all third-party reports, future City Plans, speaking with local landlords, real property owners, developers, and stakeholders to gain insight into High Point's specific market dynamics, anticipate moves local developers will make surrounding the site, and put the City in a strategic negotiating position that impact future development, and ultimate value.
  - Multifamily units drive activity, provide increased property values, and customer opportunities to surrounding office, retail, and entertainment options. The shop local movement is a strong thread in downtown revitalizations and require rooftops for support

- Retail/entertainment should accentuate unique opportunities to visit downtown, including food and beverage services and shopping that may or may not extend beyond typical office hours
- Office that provides greater downtown opportunities for government-adjacent and private services to enjoy proximity to City Hall
- Understand and develop clarity around parking needs for each use consideration, especially in concert with the stadium and other announced projects in the immediate area.
- Attend meetings and make presentations as needed to share, discuss, and provide clarity about planning, market, and construction information.
- Understanding that the City has the greatest understanding of any City zoning and planning conditions, these conditions often impact development costs and the project's marketability. TradeMark will advise on these conditions based on best practices, current market conditions, and market flexibility.
- TradeMark will engage and manage a land planning/architectural professional to develop and deliver potential development scenarios based on the above potential uses. A massing study is crucial to understanding and developing requirements for the project based on the City's desired outcomes. This information is important to attract a partner/JV developer, understand potential financing options, and a parking owner or operator aligned with the City's ultimate goals.
  - TradeMark will engage an estimator with a commercial General Contractor to provide a rough cost estimate based on current material costs to guide a strategic discussion.
  - TradeMark will provide basic underwriting for each potential use to indicate feasibility and ability to attract a developer/JV partner. The underwriting will guide recommendations for how the City might incent development or other considerations that improve the ultimate project delivery.

**Timeline:**

Upon approval and authorization of the scope of work and services agreement, TradeMark will complete the following milestones within 75 days (excluding additional administrative or procedural timelines from the City):

- Facilitate stakeholder engagement to determine City goals and priorities that drive the project
- Engage and deliver massing studies for review and discussion with High Point team
- Complete data collection and forecasting work to determine estimated costs and underwriting assumptions
- Make presentations as requested to elected officials and/or other stakeholder groups
- Make formal recommendations to the High Point team regarding market feasibility and financial stewardship

**Total Fees for Phase 1:**

- **\$120,000**
  - **35% due after presentation of massing study**
  - **50% due at presentation of the underwriting report and discussion**
  - **Balance due at presentation of TradeMark recommendations**
- **Land planning/architectural professional fees to develop and deliver potential preliminary development scenarios will be included in the TradeMark scope of work and fees**
- **TradeMark may require the engagement of the parking analysis consultant and will negotiate any additional fees in good faith to be approved and paid by the City**

***Phase 2.1 Selection of Developer Partner:***

The city is wise to use its expertise and internal staff capabilities focused on the city hall project, whether working with a developer to deliver the building and associated components or to self-deliver the building. Evaluating the balance of the uses that create critical mass and activation often requires an outside third-party review and guidance. TradeMark's goal is to augment the expertise and leadership of the team in advancing the project to approval and completion. Selecting an overall developer or a developer(s) for portions of the project might be best advised. The decision to deliver flats, multifamily units, multistory offices above the retail, or wrapping the parking deck could best be delivered by a partner developer with appropriate expertise. The ongoing operation of rental space and especially the parking could be managed more efficiently with market standard agreements within market expectations. TradeMark will develop a comprehensive outline of requirements for the City's consideration, which will, in turn, drive the next steps of project leadership and/or ownership discussions.

TradeMark will:

- Identify critical needs in the deal structure that will determine the partner selection
- Develop a project outline of options within market conditions that align with the City's goals
- Present the project criteria that the Partner must meet, i.e.: uses, planning and construction delivery, and parking
- Detail covenant/declaration considerations for design and future management/operation
- Work with legal and accounting professionals to understand and recommend default protection structure
- Propose Architectural Review Committee representation-design of the exterior, lobby areas, and building materials
- Develop appropriate marketing materials and use market-appropriate methodologies to identify and evaluate partner options. The massing study will be critical as partners consider the options for the project and the City's requirements



- Present an analysis outlining the potential partner's qualifications and response to the project
- Recommend shortlist and facilitate discussions and negotiations for an ultimate JV/partner, ground lease agreement or sale of real property

**Timeline:**

Upon notification from the High Point team that the Phase II scope of work services agreement has been approved, including marketing methodologies, timeline, and Partner criteria, within 30 days, TradeMark will develop a Request for Proposal for review and approval of the HP team. We will market to customary channels, including an exclusive internal list of over 4,000 known developers and investors nationwide.

**Total Fee for Phase 2:**

Identify, negotiate, and complete representation agreements. The representation agreement will include defined value criteria to allow for the options under consideration by the City, such as a ground lease, JV, or sale.

Tasha, we have enjoyed the opportunity to understand the potential development to enhance downtown, deliver a new city hall, and create new options to live, work, and play in the City of High Point. We look forward to our subsequent discussions.

Sincerely,

The image shows two handwritten signatures in black ink. The signature on the left is 'Billie Redmond' and the signature on the right is 'Jonathan Bassi'.

Billie Redmond and Jonathan Bassi

